



PRODUCT BULLETIN #526

D160 FORTRESS HUB & SPINDLE UPDATE

April 8, 2026

Dexter is pleased to announce the release of an updated D160 hub-and-spindle combination. This new design allows for the use of the bolt-on Fortress® bearing protection system and the Dexter medium duty spindle nut retention system, providing enhanced serviceability and retention performance.

The updated D160 hub is manufactured in the USA and uses an M22 wheel stud, available in standard or optional long thread length.

The new D160 spindle continues to use the same bearing and seal combination as the previous design; however, it eliminates the cotter pin. Instead, it incorporates Dexter's keyway design for use with the Dexter medium duty double-nut/star-washer retention system.

For service and replacement purposes, the updated D160 hub-and-spindle assembly is not interchangeable with the legacy design. Although bearing and seal components remain common, hub-and-spindle interfaces differ between designs, and hubs must be matched to their corresponding spindles. Installation of a new-design hub on a legacy spindle, or a legacy hub on a new-design spindle, is not approved. Dexter will continue to offer the obsolete hub design for service support of existing axles, while all future replacement axles will be supplied exclusively with the updated D160 spindle and Fortress hub configuration.

D160 AXLE ASSEMBLY

	PART NUMBER	DESCRIPTION
1	005-060-00	WASHER, SPINDLE
2	006-084-00	NUT, SPINDLE
3	005-059-00	LOCKWASHER, SPINDLE
4	007-684-00	SOCKET HEAD CAP SCREW & WASHER
5	021-259-00	BOLT-ON FORTRESS CAP ASSEMBLY 10K - 16K
6	010-500-00	CAP, OIL GASKET
7	008-561-08 008-561-18	16K HUBS - 275MM 16K HUBS - 275MM - OPTIONAL LONG WHEEL STUD

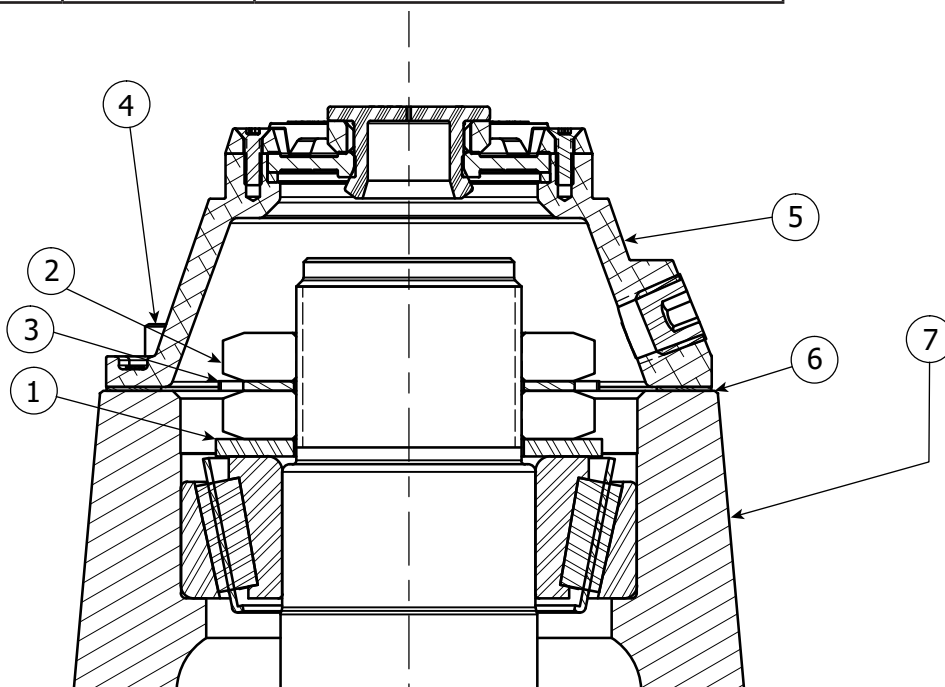

OBSOLETE 16K AXLE ASSEMBLY

	PART NUMBER	DESCRIPTION
1	005-331-00	WASHER, ROUND
2	006-297-00	NUT, 1 3/4" - 12, 6 SLOTS
3	021-226-00	OIL CAP, LEGACY 16K
4	019-040-00	PIN, COTTER, 1/4" X 3.00 LONG
5	010-126-00	O-RING, OIL CAP
6	008-095-08	HUB 16K - 8-275MM

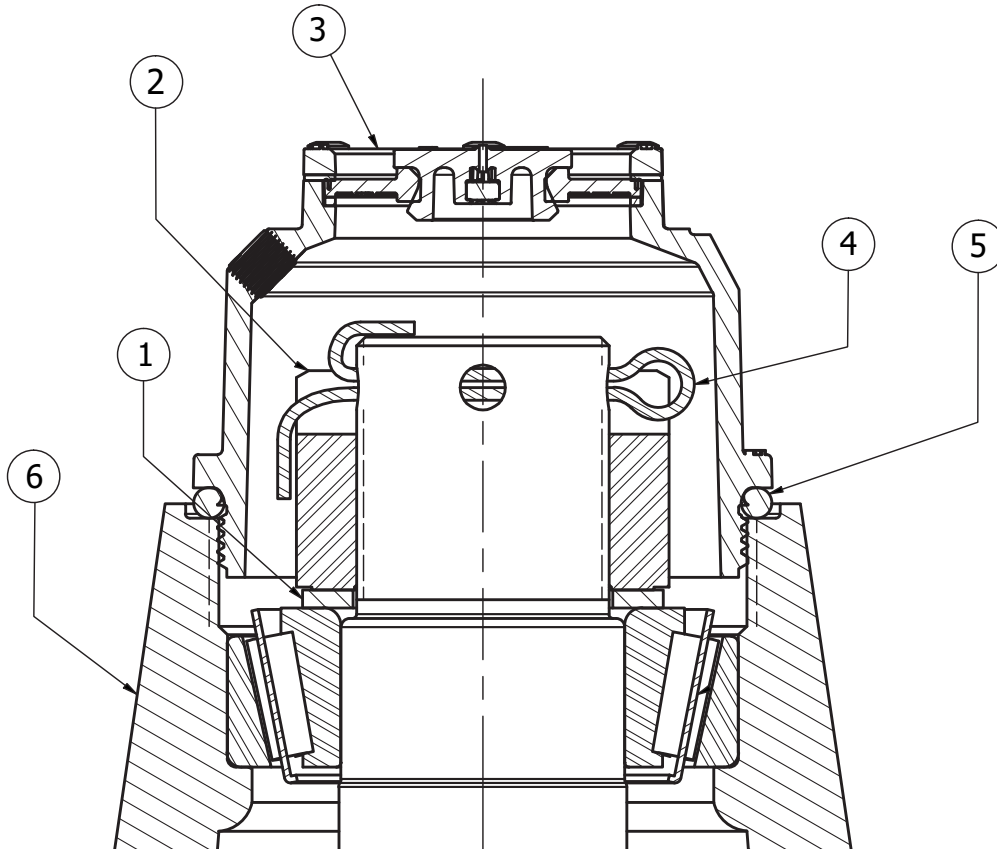

Please contact your Dexter account manager for additional information and further assistance.

Mark Nave
Product Manager