

Date: February 25, 2020

Subject: Type 26 Torpress Actuator Pad Change to One-Piece Design

In keeping with Dexter's commitment to product innovation, we are pleased to communicate a change from a multi-piece weldment to a one-piece design for the type 26 Torpress actuator pads on SMART-STEER axles. There is no impact to fit, form, or function of this new design. Old pads and new pads are interchangeable in the field. This change will be implemented immediately to enhance production efficiency and bolster the reliability of the product.

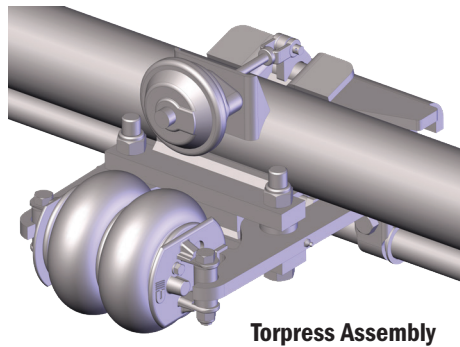

The affected Torpress models are listed below:

MODEL NUMBER	
700326	702871
701601	702931
702151-01	702937
702837	703002

Type 20 Torpress actuator pad change to follow later this year.

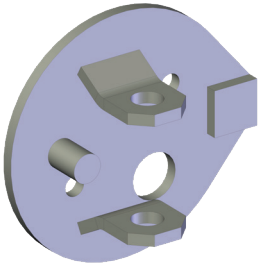
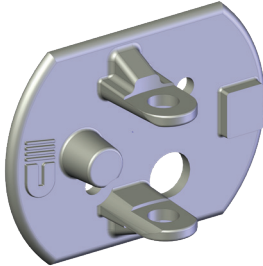
OLD MULTI-PIECE DESIGN		NEW ONE-PIECE DESIGN	
Old Part Number		New Part Number	
700330 (RH)	700332 (LH)	703033-RH	703033-LH
			

Please contact your Dexter Heavy Duty account manager if you have additional questions or need further assistance.



Neil Haslam
Engineering Manager, Heavy Duty