

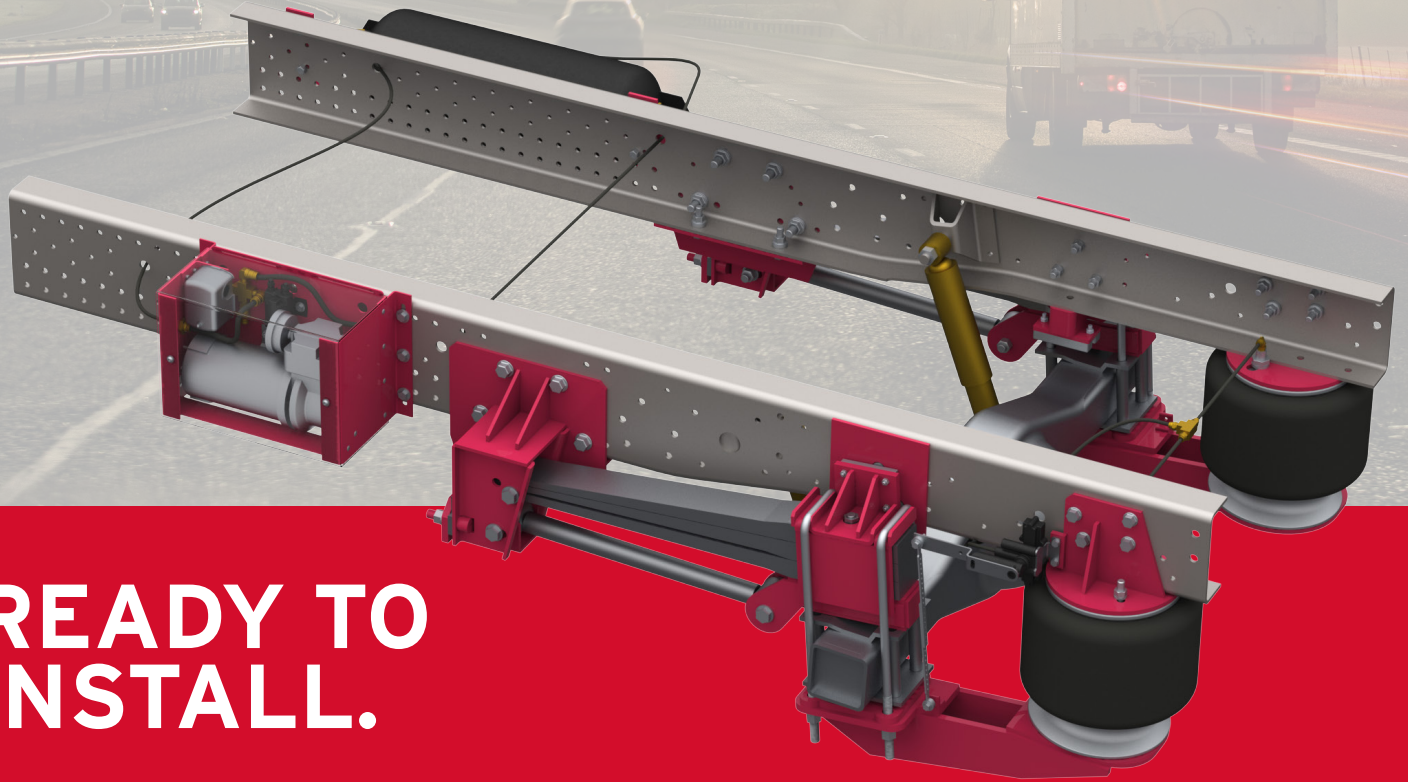

ALD SERIES SUSPENSION TRUCK DRIVE AXLE AIR UPGRADE



**READY TO
INSTALL.**

SOFT AND STABLE RIDE FOR COMFORT

- » Ride height controls and air springs provide a smoother ride
- » Provides superior performance and safety features over the factory-installed suspension
- » Fits a wide range of frames for ambulances, shuttle buses, work trucks, and motor homes

QUICK AND EASY INSTALLATION

- » For trucks with drive axle GAWR of 7,800-23,000 lbs.
- » 100% self-contained option includes air compressor and all installation components
- » Easy, bolt-on installation to existing frames where possible

COMFORT AND STABILITY

» LIGHTWEIGHT DESIGN, HEAVY DUTY SUPPORT

- Designed around OEM chassis to minimize frame stress without affecting the truck's carrying capacity
- Automatic height control valve helps maintain the optimum ride height whether vehicle is loaded or unloaded
- Reversible sleeve style air spring provides a more comfortable ride
- Internally mounted brackets and rods control axle movement allowing for positive alignment
- Pivot points equipped with long lasting lubrication-less urethane bushings
- Dual height control valve option helps maintain ride height from side to side
- Cab operated rear suspension dump valve system available
- Designed, manufactured, and supported by Dexter, with over 60 years of experience
- Available add-ons: air compressor, air control kit, lines and fittings

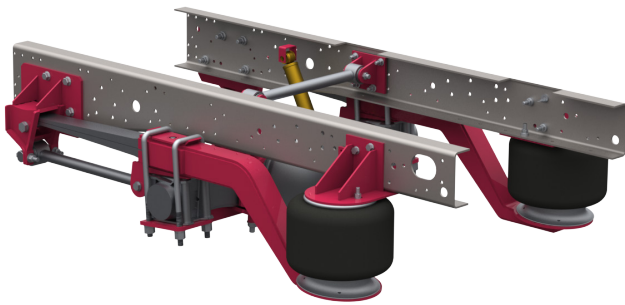

ALD-320 SERIES

11,000 - 18,000 lbs. GAWR drive axle trucks

Up to 13,500 lbs. suspension capacity

Designed to fit: Ford®, Chevy®, Isuzu®, Mitsubishi®, Hino®, UD®

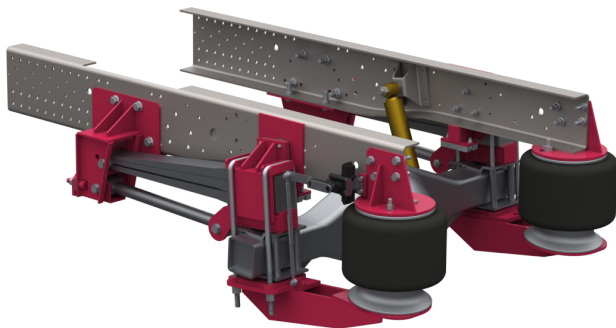

ALD-330 SERIES

16,000 - 33,000 lbs. GAWR drive axle trucks

Up to 23,000 lbs. suspension capacity

Designed to fit Ford®, Freightliner®, GM®, International®, Isuzu®, Mitsubishi®, Hino®, UD®



www.dexteraxle.com