



STEER AXLE SYSTEMS

HEAVY DUTY TRAILER SOLUTIONS



**LOAD TESTED,
ROAD PROVEN.**

MANEUVERABLE AND STABLE

- » Manufactured using state-of-the-art friction welds stronger than plug welds, increasing stability and product life
- » Superior turn radius helps reduce tire wear
- » Long-lasting induction heat-treated spindles

SUPPORT EVERY STEP OF THE WAY

- » Over 60 years of axle design and manufacturing experience
- » Engineering support to create custom configurations to match your specifications
- » Exceptional customer service and technical field support team to support you after purchase

SMART-STEER® DIFFERENCE

» TRUSTED DURABILITY

- Load tested to the breaking point, to ensure your safety on the road
- High-strength forged steel components
- Leading kingpin design for optimum control and performance
- Strongest, most innovative self-steer axle on the road
- Increases trailer load carrying capacity and trailer stability
- Utilizes industry standard components for optimum durability and easy installation
- Compatible with various sizes of drum and disc brakes

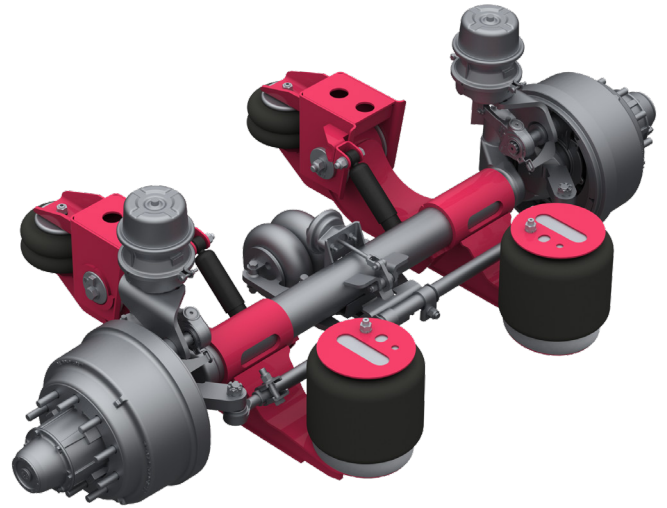
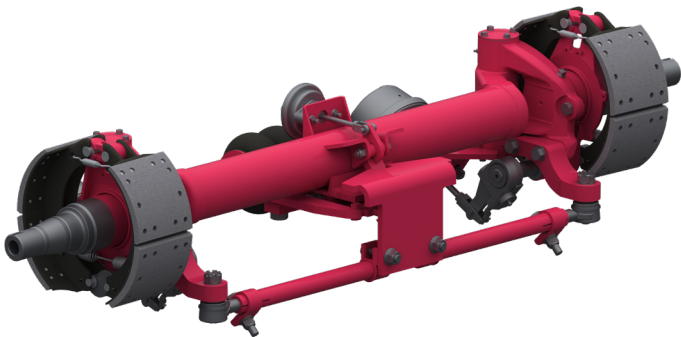

» FEATURES:

Track lengths up to 140"

Capacities up to 25,000 lbs.

Integrated air ride suspensions available

Tire inflation system ready

SPIF compliant design

Dual draw key kingpin design

Multiple lock mechanism designs available

» SUPERIOR TURN RADIUS

- Increases trailer maneuverability
- Less scrubbing provides longer tire life and less frame stress
- Adjustable steer stops to maximize turn angles up to 30°

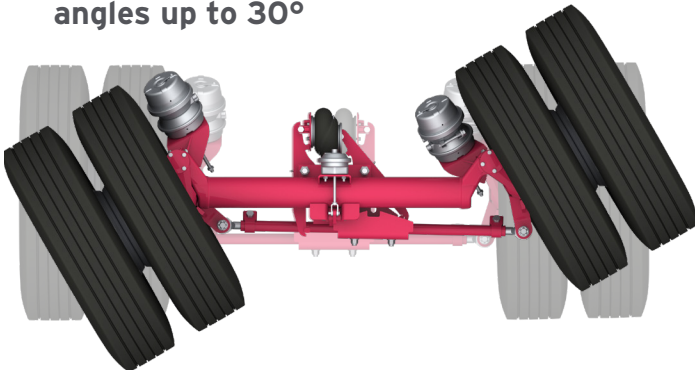

» SMART TORPRESS

- An advanced center-steer, turn damper provides true-tracking stability
- Provides increased life, better performance, and pressure-sensing capability
- Removes the need for the proportioning valve, regulators, pressure valves and air hoses
- More reliable and easier to service

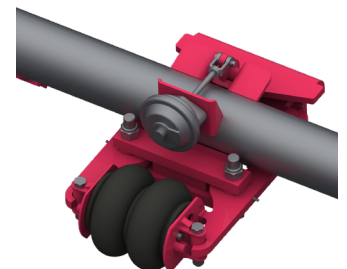

www.dexteraxle.com

OPTIONS & SPECIFICATIONS

» INTEGRATED EXPANSION TANK OPTION

- The industry's only self-steer axle beam with integrated expansion tank option
- Patented design eliminates external expansion tanks saving room, weight, and money
- Plug and play system includes axle preparation, fittings, air brake tubing and drain
- Tested in accordance with SAE J10 specifications

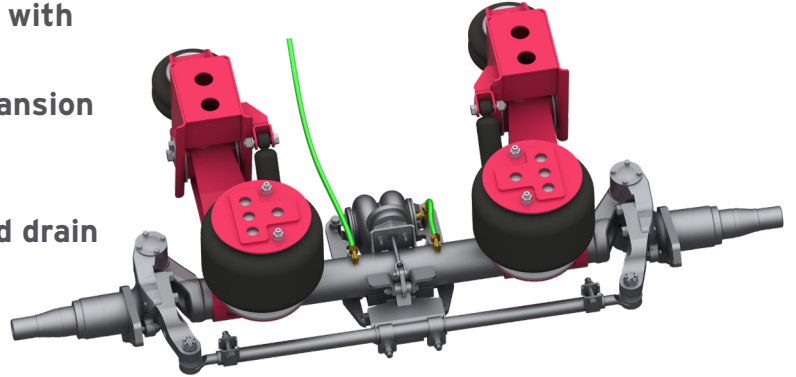

» BEAM UPGRADE OPTIONS

LARGE DIAMETER

Perfect for weight-sensitive applications, saves 25-30 lbs. per axle



DROP CENTER

Standard and inverted
6" or 9" drops

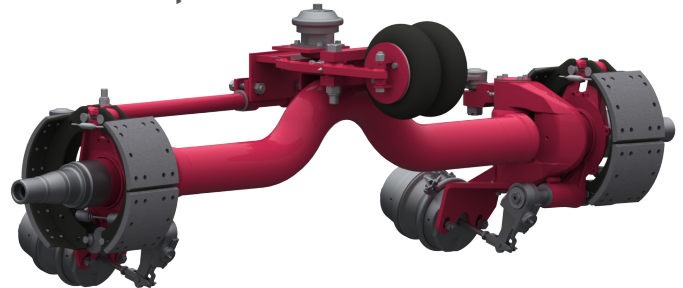

FORCED STEER AXLES

» IN-LINE KINGPIN

- Significantly improves the maneuverability by reducing turn radius, forwards and backwards
- Wheels can be rotated without scrubbing the tires even if the trailer is stationary
- High-strength bolt-on steer arms allow for a flexible design
- Double acting, 3,000 psi rated hydraulic cylinder package available
- Automatic steer system compatible
- Utilizes industry standard components for optimum durability and easy installation

» FEATURES:

Track lengths up to 140"

Capacities up to 25,000 lbs.

Integrated air ride suspensions available

Compatible with various sizes of drum and disc brakes

Dual draw key kingpin design

Multiple lock mechanism designs available

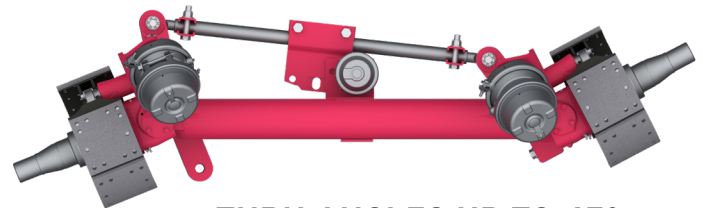
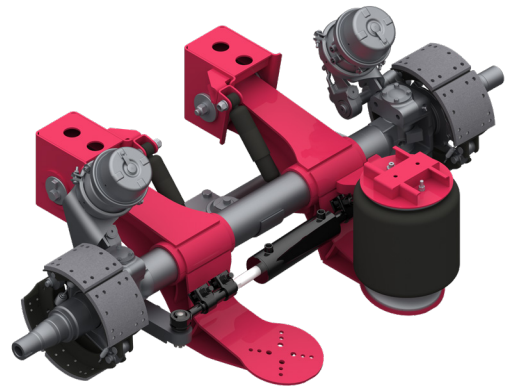
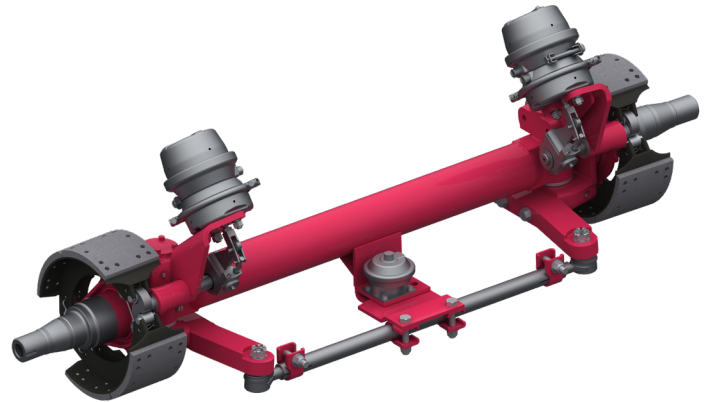

TURN ANGLES UP TO 45°

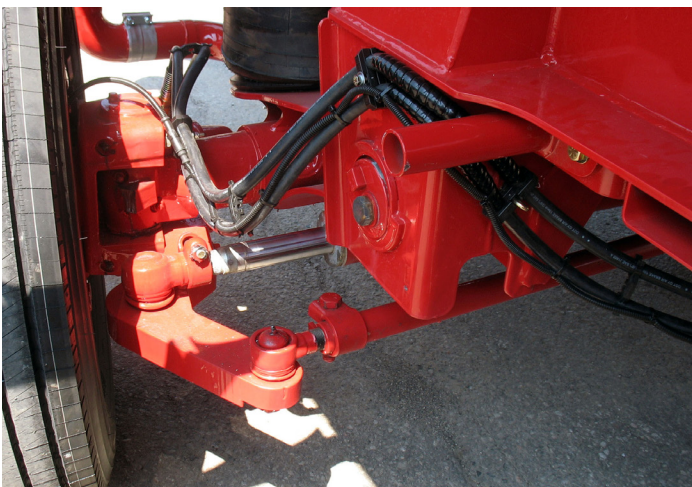

www.dexteraxle.com

© 2023 Dexter Axle Company | LIT-427-00 | 2023.06