



MEDIUM DUTY CATALOG

9,000 - 15,000 LBS. AXLE CAPACITY



Table of Contents



Introduction	2	Suspensions.....	20
Video Gallery.....	3	Dexter Axle Suspension System	20
Required Axle Dimensions & Features	4	Cross Frame Hanger Reinforcement.....	20
Options for Spring Suspension Axles.....	4	Single Slipper	21
Options for Torflex® Suspension Axles	4	Kits for 2" Wide Springs.....	21
Dexter Medium Duty Utility Axle Beam Features	5	Kits for 2½" Wide Springs ¾" Spring Eye Bolts	22
Torflex® Axle Beam Features	5	Kits for 3" Wide Springs.....	23
9K-10K GD Capacity:		Double Slipper	24
#13G Torflex®/D90-D100G Leaf Spring	6	HDSS Underslung.....	24
Torflex® Application Information.....	6	HDSS Overslung.....	25
9K, 10K, and #13G General Duty Two-Piece Hubs....	7	Airflex® Suspension	26
9K, 10K, and #13G General Duty One-Piece Hubs...8	8	Wheel & Hub Assembly.....	27
9K, 10K, #13G, #14T General Duty Two-Piece Hubs.9	9	10,000 Lb. Heavy Duty Wheel & Hub Assembly	27
10K-15K Capacity:		12,000 Lb. Wheel & Hub Assembly	28
#13D & #14 Torflex® /		15,000 Lb. Wheel & Hub Assembly	28
D100, D120 & D150 Leaf Spring.....	10	Wheels and Tires.....	29
Torflex® Application Information 12,000 Lbs.....	10	Axle Overhang.....	29
10K, 12K, 15K, #13D, and #14 Hubs.....	11	Oil Lubrication Specification	30
Medium Duty Axle Brakes	12	Bearing Adjustment	30
Electric Brakes.....	12	Warranty	31
Forward Self-Adjusting Electric Brake	12	Locations	32
Typical Electric Brake Wiring Diagram	12		
Electric Brake Parts - Cast Backing Plate	13		
Electric Brake Parts - Stamped Backing Plate.....	14		
Hydraulic Brakes.....	15		
Forward Self-Adjusting Hydraulic Brake & System Diagram	15		
Hydraulic Brake Parts	16		
Disc Brakes.....	17		
10K, 12K, #13G, #13D and #14 Hydraulic Disc Brake	17		
Hydraulic Disc Brake Parts.....	17		
Air Brakes	18		
Dexter "S" Cam Brake	18		
Small "S" Head Hi-Rise 28 Spline.....	18		
Typical Air Brake System Diagram	18		
Air Brake Parts - "PQ" Style.....	19		

Introduction



This information is intended as a guide for the proper specification and application of Dexter Axle running gear, associated components and accessories.

Dexter offers a full line of trailer axles that can be used in many different applications. When specifying any pre-engineered components such as axles, it is the responsibility of the trailer designer to insure compatibility with the vehicle and all of its sub-systems.

Information

The information presented is meant to assist trailer manufacturers in the specification of their running gear components. Dexter Axle does not warrant that the information given constitutes an approved trailer design or application. Dynamic loading, travel requirements unique to the trailer design, unusual service conditions, trailer configurations, unequal load distribution, hitch or coupler arrangements and towing vehicle suspension characteristics can significantly affect the performance of any trailer axle and/or suspension systems. It remains the responsibility of the trailer manufacturer to evaluate, specify and test their trailer/running gear combination before production and to certify it as such. While the information presented at the time of this writing is current, it is subject to change as designs and components evolve over time.

Disclaimer of Warranty and Limitation of Liability

All users of this product catalog acknowledge that the information presented is significantly affected by factors within the exclusive knowledge of the user including, among other things, service conditions, trailer configurations, load distributions, hitch and coupler arrangements and tow vehicle suspension characteristics, that the users have independently investigated these factors and have solely relied on those investigations when using this catalog, and that it is the responsibility of the user to adequately specify, evaluate and test its trailer/running gear combinations.

DEXTER AXLE DISCLAIMS ALL WARRANTIES, WHETHER WRITTEN, ORAL OR IMPLIED, IN FACT OR IN LAW (INCLUDING ANY WARRANTY OF MERCHANTABILITY OR FITNESS FOR A PARTICULAR PURPOSE), ASSOCIATED WITH THE USE OF THE CATALOG AND WITH ANY INFORMATION PRESENTED BY THIS CATALOG.

Dexter Axle shall not be liable in damages (whether compensatory, punitive, direct, indirect, special, incidental or consequential) to any user of this catalog under contract, tort, strict liability or any other theory of liability, and any user agrees to indemnify and hold Dexter Axle harmless from any and all claims, actions or other proceedings (including attorney fees and court costs) arising out of the use of this catalog to the extent said claims, actions or other proceedings do not arise out of the sole and exclusive negligence of Dexter Axle.

Load Ratings

The maximum load carrying capacity of any assembly is limited

to the lowest load rating of any individual component selected. For instance, the load rating of a pair of wheels may be lower than other axle components selected. If this is the case, the load carrying capacity of the axle assembly is reduced accordingly. As a specific example, if a pair of wheels is rated at 1500 pounds each and is used with other components rated at 4000 pounds per axle, the maximum load capacity is limited to 3000 pounds. If two tires are rated at 1400 pounds each and are used on this assembly, the maximum load carrying capacity is limited to 2800 pounds.

Axle Orientation

When working with trailer running gear, it is important to understand the various features and descriptions of the equipment. Most trailer axles are directional by nature, that is, it is imperative that they be installed onto the trailer in the proper manner to ensure brake functioning and correct wheel alignment. The front of the axle must be oriented toward the front of the trailer. The convention used to define right and left is based on viewing the trailer from the rear and facing in the direction of forward travel.

Features to help identify the front of the axle:

- Electric brake wires exit brake backing plates toward the rear of the axle.
- 12 $\frac{1}{4}$ " hydraulic brakes have view ports through the dust shield on the back of the assembly. Where the brake lining is visible in the view port, that will indicate the rear or secondary shoe which is always oriented toward the rear of the axle.
- Slipper springs have the spring eye at the front of the axle.
- Leaf spring axles with inner wiring have the wires exit the tube toward the rear of the axle.
- Torflex® axles have the wheel center trailing behind the axle tube.
- Axles using $\frac{3}{4}$ " spherical ball seat wheel nuts will have right and left handed threads. The right handed thread must be on the right end or curb side of the axle while the left handed thread will be on the left end or road side of the axle.

Stub Axle Disclaimer

A stub axle is described as a trailer axle spindle, welded to a short length of tubing. Stub axles may be specified and purchased as plain spindle/tube weldments or they may be fully assembled wheel end units, with or without trailer brakes.

These incomplete axles are sold to manufacturers who wish to incorporate them into a variety of applications such as specialty vehicular axles, belt tensioning devices, machinery pivot points, etc.

DEXTER AXLE HAS NO CONTROL OF THE DESIGN INTENT OF THESE SPECIAL APPLICATIONS AND THEREFORE CANNOT APPLY A RATING OR CAPACITY TO THESE COMPONENTS.

The spindle/tube connection has been designed for suitable stress levels when used in a trailer axle, mounted to an approved suspension system and loaded to no more than the stated

capacity. The use of all or part of the product for applications other than its intended purpose may not be appropriate. It is the customers' responsibility to determine the efficacy and safety of their particular application.

Torflex® axles can also be purchased as stub axles. This type of axle incorporates a self-contained suspension system. They can be specified as stub assemblies that will be rated for capacity when fitted with approved mounting brackets. The stated capacity will be based on the lowest rated component in each assembly.

These stub assemblies are essentially half axles that are intended to be mounted to the trailer chassis independent of each other. The trailer manufacturer must assume responsibility for the integrity of the attachment as well as the final wheel alignment since independent mounting puts these critical aspects out of Dexter's control. If used in pairs of unequal capacity, the trailer manufacturer should assign a Gross Axle Weight Rating of not more than two times the capacity of the lower rated sub assembly.

Video Gallery

In keeping with our continual commitment to industry safety and the development of innovative products, please feel free to view our ongoing video gallery at www.dexteraxle.com/resources/videos or scan the following QR codes. We are confident these videos will help educate and promote the Dexter product line that you, as our customer, are investing in.



[Bearing Maintenance](#)



[E/H Actuator Installation](#)



[Electric Brakes](#)



[E-Z FLEX® Suspension](#)



[TORFLEX® Suspension Axles](#)



[E-Z LUBE® System](#)



[Genuine Brakes](#)



[Genuine Replacement Parts](#)



[Leaf Spring Axles](#)



[Sway Control](#)



[Manual Bleed Hydraulic Disc](#)



[Medium Duty Axles](#)



[Nev-R-Adjust® Brakes](#)



[Power Bleed Hydraulic Disc](#)



[Removable Spindle](#)

Options for Spring Suspension Axles



Hubface – Track Width – Spring Center

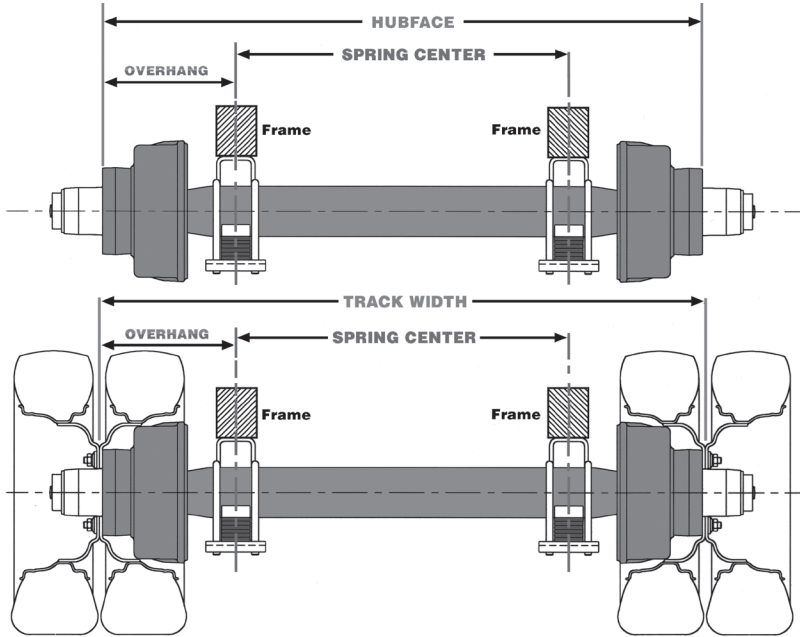

Wheel Offset

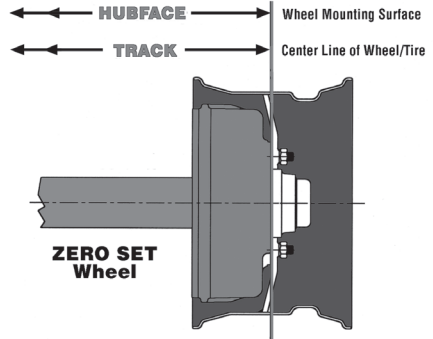
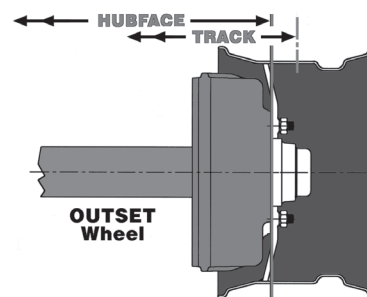
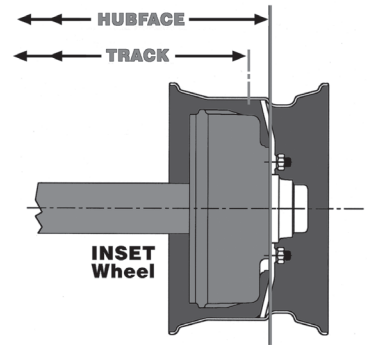

Axle Spacing

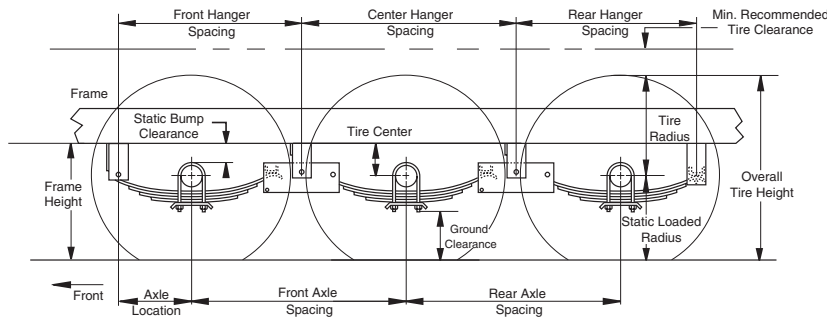

Options for Torflex® Suspension Axles

Bracket Orientation

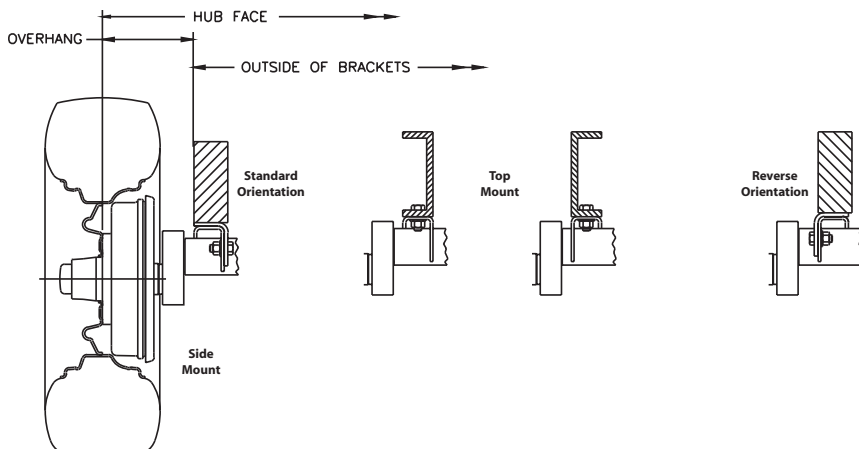

Bracket Profile

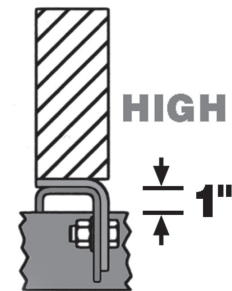

Dexter Medium Duty Utility Axle Beam Features

- Highest strength axle tube generally available for utility vehicle axles.
- Materials used allow a stiffer and stronger axle beam with no camber required.
- The backing plate of the Dexter electric or hydraulic brake mounts on piloted axle brake flange. This assures that brakes will perform effectively.

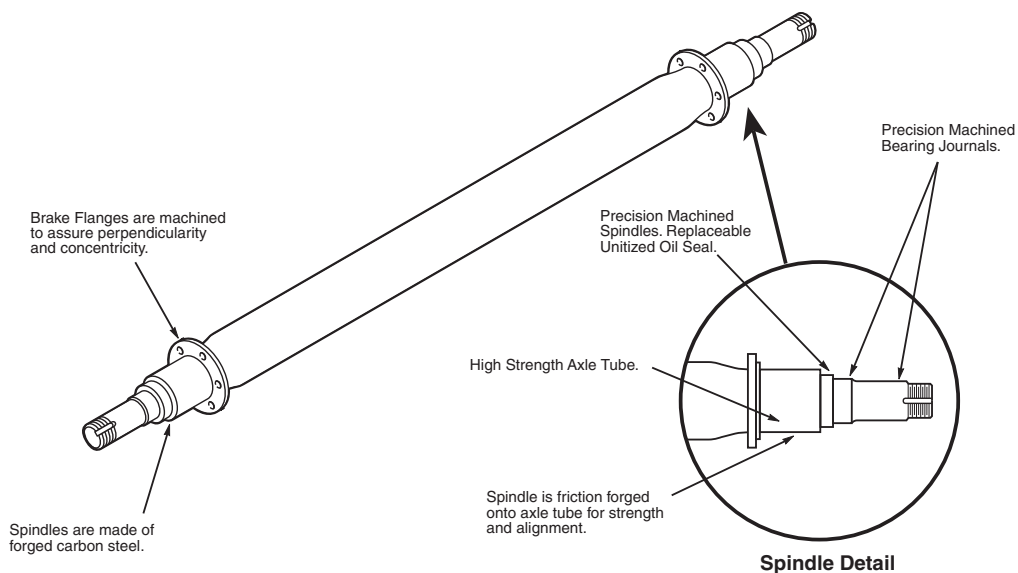

REQUIRED AXLE DIMENSIONS & FEATURES

Torflex® Axle Beam Features

#13G – General Duty

#13D – Heavy Duty

#14

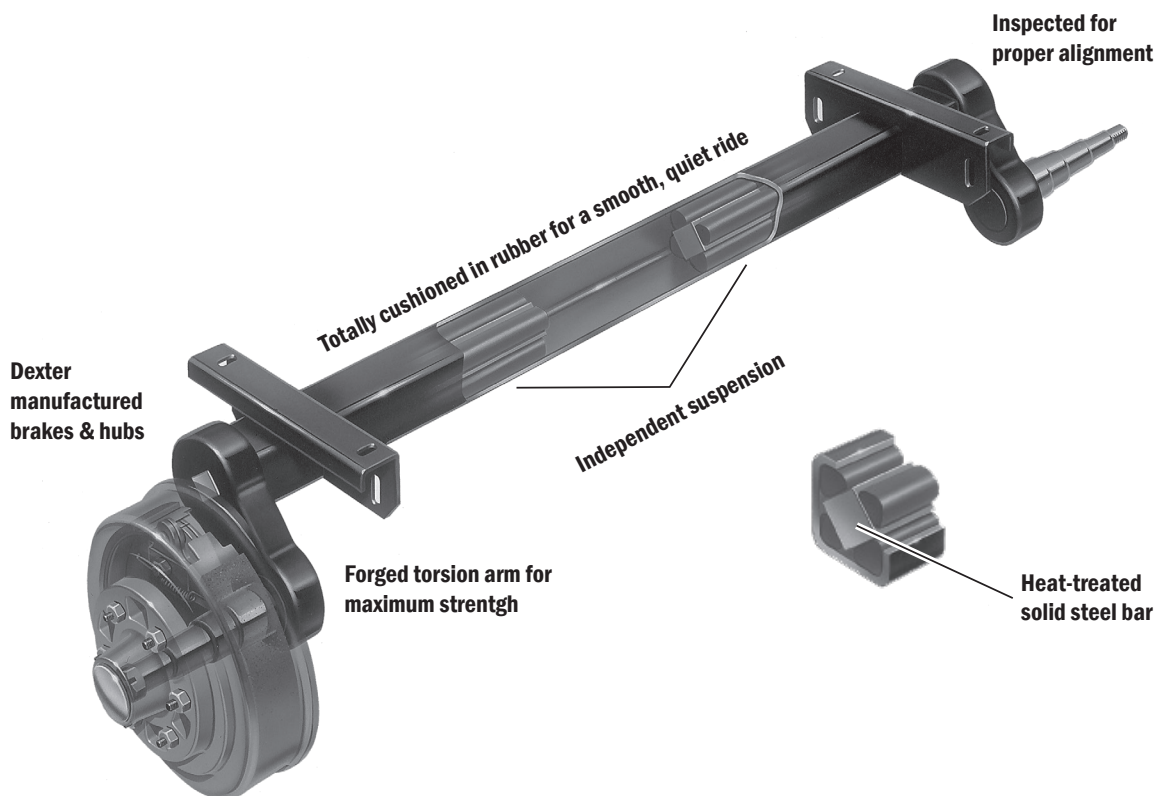

CAUTION: Triple axle assemblies are NOT recommended for #13 or #14 Torflex® axles.

Torflex® Application Information



Articulation Dimensions

Dimensions are for high profile, top mount only. Side mount is .31" higher. Allow 3" bump clearance from full load.

Start Angle	Bracket Profile	No Load		Full Load		Shock Load	
		H	L	H	L	H	L
45° Down	High	7.18	4.24	5.24	5.54	4.24	5.83
32° Down	High	6.12	5.09	3.93	5.92	2.94	5.84
22.5° Down	High	5.24	5.54	2.94	6.00	1.90	5.91
10° Down	High	3.98	5.91	1.64	5.86	0.64	5.54
0°	High	2.94	6.00	0.64	5.54	-0.28	5.06
10° Up	High	1.90	5.91	-0.28	5.06	-0.11	4.42
22.5° Up	High	0.64	5.54	-1.30	4.24	-1.97	3.44

Overhang Per Side

Spindle	Min.	Max.	Brake
#13D	12.25"	17.20"	12¼" x 4"
#13G one-piece	10.11"	17.20"	12¼" x 3⅜"
#13G two-piece	11.35"	17.20"	12¼" x 3⅜"

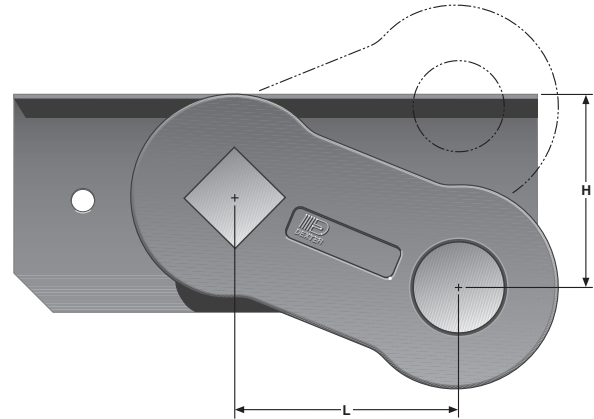

Note: Positive numbers in the H column indicate the spindle is BELOW the top of the bracket. Conversely, negative numbers are ABOVE the top of the bracket.

Note: Dual wheel not available for #13G one-piece. One-piece hub/drum is not interchangeable with the two-piece hub & drum.



Full Load Dimensions

Dimensions are for high profile, top mount only. Side mount is .31" higher. Allow 3" bump clearance from full load.

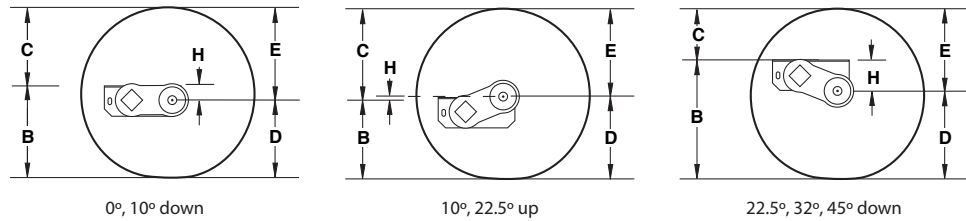

Start Angle

Tire	* **		45° Down			32° Down			22.5° Down			10° Down			0°			10° Up			22.5° Up		
	D	E	H	B	C	H	B	C	H	B	C	H	B	C	H	B	C	H	B	C	H	B	C
LT235/85R16	14.3	15.4	5.2	19.5	10.2	3.9	18.2	11.4	2.9	17.2	12.5	1.6	15.9	13.8	.6	14.9	14.8	-0.3	14.0	15.7	-1.3	13.0	16.7
215/75R17.5	14.0	15.3	5.2	19.2	10.1	3.9	17.9	11.3	2.9	16.9	12.4	1.6	15.6	13.7	.6	14.6	14.7	-0.3	13.7	15.6	-1.3	12.7	16.6
235/75R17.5	14.3	15.7	5.2	19.5	10.5	3.9	18.2	11.7	2.9	17.2	12.8	1.6	15.9	14.1	.6	14.9	15.1	-0.3	14.0	16.0	-1.3	13.0	17.0
9R17.5HC	15.4	17.1	5.2	20.6	11.9	3.9	19.3	13.1	2.9	18.3	14.2	1.6	17.0	15.5	.6	16.0	16.5	-0.3	15.1	17.4	-1.3	14.1	18.4
10R17.5HC	15.6	18.0	5.2	20.8	12.8	3.9	19.5	14.0	2.9	18.5	15.1	1.6	17.2	16.4	.6	16.2	17.4	-0.3	15.3	18.3	-1.3	14.3	19.3

Columns D and E are dimensional examples only:

* D – Static Loaded Radius

** E – Inflated Radius

#13D & #13G Bracket Dimensions

A	1.22
B	3.63
C	10.56
D	10.56
E	13.00
F	5.50
G	2.50
H	2.25
I	7.26
J	1.00
K	1.00
Bolt Size	5/8" bolt
Tube Size	3.88

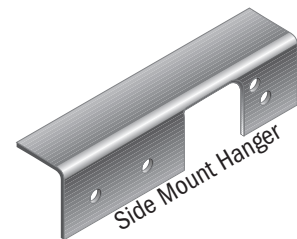
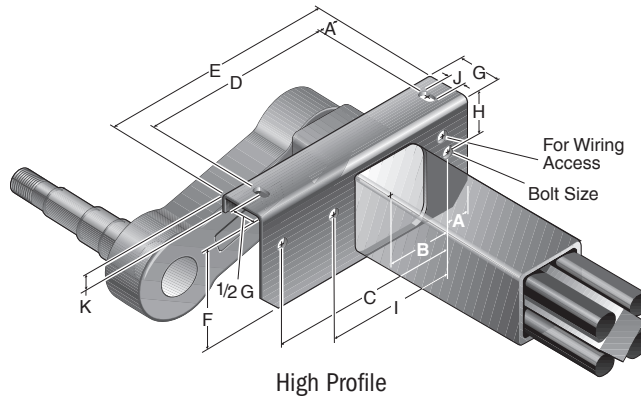

9K, 10K, and #13G General Duty Two-Piece Hubs



9,000-10,000 GD CAPACITY

After April 2013

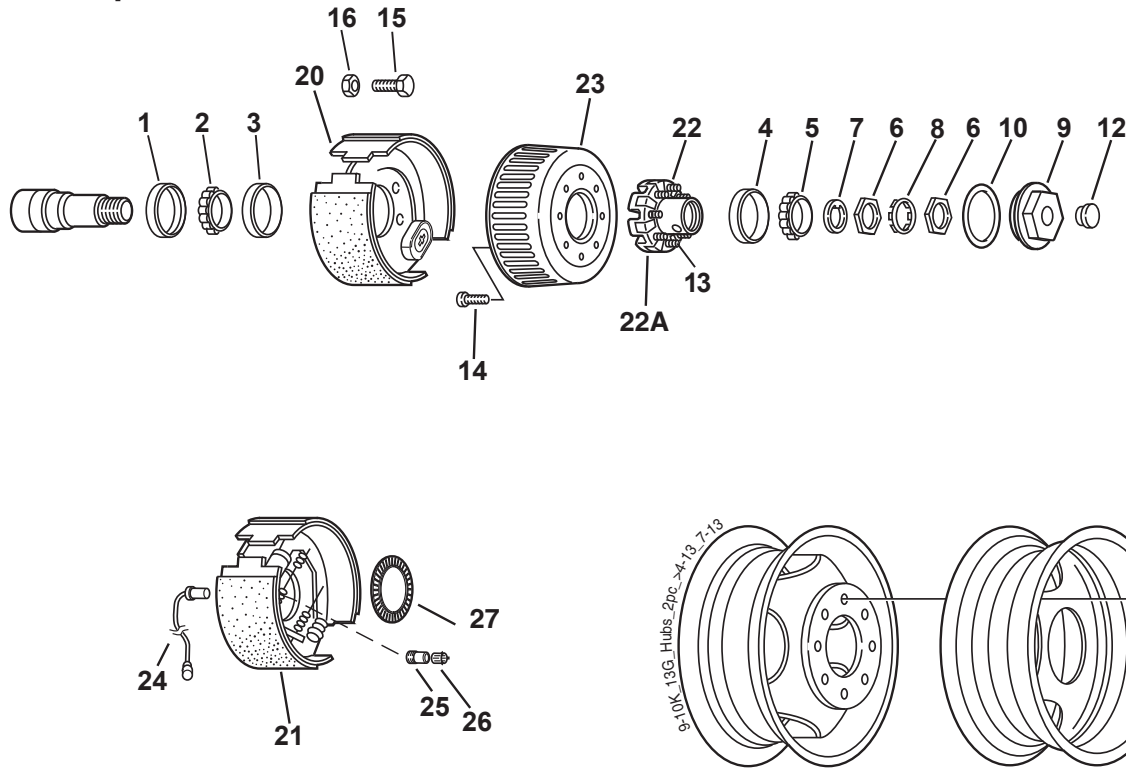

Standard Oil Lube Parts

Item	Part No.	Description
1	010-051-02	Oil Seal
2	031-019-02	387A Inner Bearing Cone
3	031-019-01	382A Inner Bearing Cup
4	031-030-01	25520 Outer Bearing Cup
5	031-030-02	25580 Outer Bearing Cone
6	006-096-00	Spindle Nut (2)
7	005-070-00	Spindle Washer
8	005-071-00	Tang Washer
9	021-088-00	Oil Cap
10	010-163-00	'O' Ring
12	046-032-00	Oil Cap Plug
13	007-115-00	5/8-18 Wheel Stud
14	007-292-00	Drum Mounting Screw
15	007-116-00	Brake Mounting Bolt
16	006-017-00	Brake Mounting Nut
ns	005-008-00	Lockwasher

Hub & Drum

Item	Part No.	Description
ns	008-430-05	Oil Hub and Drum w/Cups and Studs
22	008-430-03	Oil Hub w/Cups and Studs
23	009-123-01	Drum - Machined
ns	008-430-07	Oil Hub and Drum w/Cups and Studs ABS
22	008-430-03	Oil Hub w/Cups and Studs
ns	009-123-03	Drum - for ABS

ns - not shown

12 1/4" x 3 3/8" Brakes

Item	Part No.	Description
20	K23-450-00/K23-451-00	LH/RH Electric, FSA
21	K23-410-00/K23-411-00	LH/RH Hydraulic, FSA, Duo-Servo
21	K23-210-00/K23-211-00	LH/RH Hydraulic, RSA, Du-Servo w/Park
ns	K23-412-00/K23-413-00	LH/RH Hydraulic, FSA, Single-Servo
ns	K23-234-00/K23-235-00	LH/RH Hydraulic, Manual Adjust Single-Servo w/Park

ABS Components

Item	Part No.	Description
24	097-004-00	Sensor, Straight
25	024-204-00	Sensor Block
26	097-002-00	Sensor Clip
27	024-205-01	Tone Ring
ns	007-248-00	Tone Ring Screws

Studs and Wheel Nuts

Item	Part No.	Description	Nut Torque
18*	006-109-00	5/8-18 90° Cone Nut	200 lbs.-ft
19*	033-052-01	Clamp Ring	
17	006-058-00	5/8-18 Flange Nut	300 lbs.-ft
13	007-115-00	5/8-18 Press-in Stud	

* Must use the 90° cone nut with the clamp ring. Alternate fastener is just the flange nut.

9K, 10K, and #13G General Duty One-Piece Hubs



After July 2009

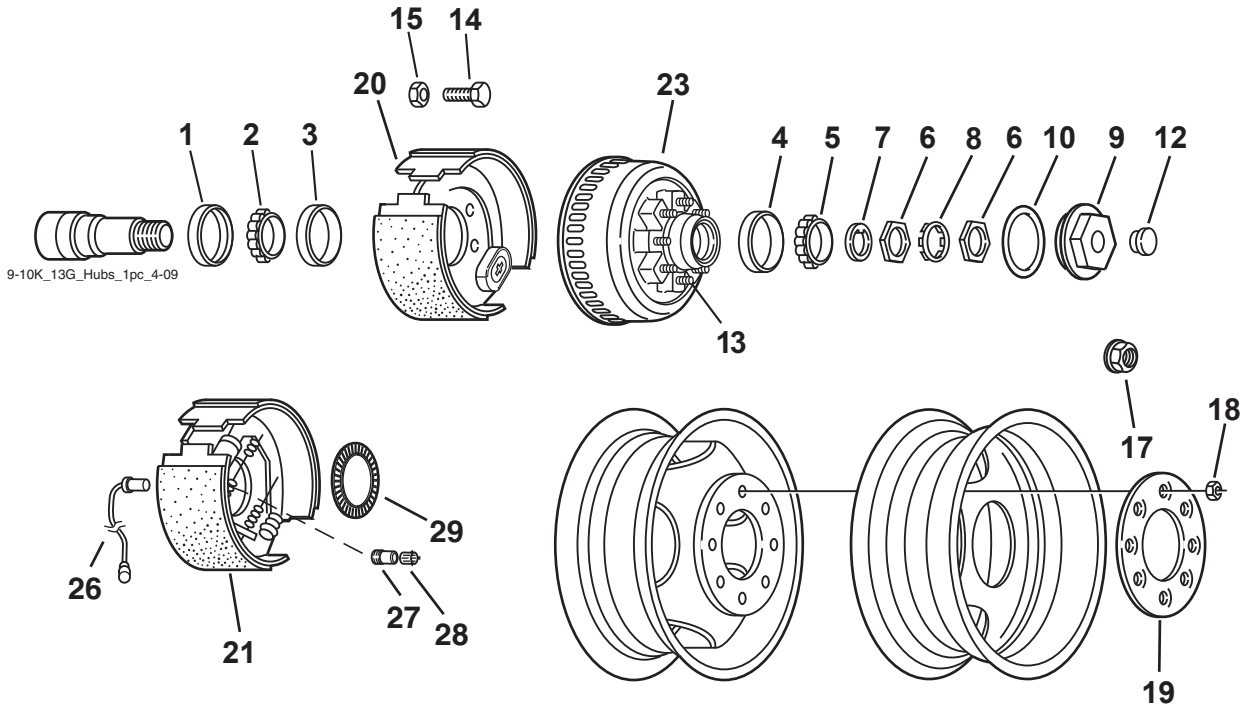

Note: Dual wheel cannot be used with 13G

Standard Oil Lube Parts

Item	Part No.	Description
1	010-051-02	Oil Seal
2	031-019-02	387A Inner Bearing Cone
3	031-019-01	382A Inner Bearing Cup
4	031-030-01	25520 Outer Bearing Cup
5	031-030-02	25580 Outer Bearing Cone
6	006-096-00	Spindle Nut (2)
7	005-070-00	Spindle Washer
8	005-071-00	Tang Washer
9	021-088-00	Oil Cap
10	010-163-00	'O' Ring
12	046-032-00	Oil Cap Plug
13	007-115-00	5/8-18 Wheel Stud
14	007-116-00	Brake Mounting Bolt
15	006-017-00	Brake Mounting Nut
ns	005-008-00	Lockwasher

12 1/4" x 3 3/8" Brakes

Item	Part No.	Description
20	K23-450-00/K23-451-00	LH/RH Electric, FSA
21	K23-410-00/K23-411-00	LH/RH Hydraulic, FSA, Duo-Servo
21	K23-210-00/K23-211-00	LH/RH Hydraulic, RSA, Du-Servo w/Park
ns	K23-412-00/K23-413-00	LH/RH Hydraulic, FSA, Single-Servo
ns	K23-234-00/K23-235-00	LH/RH Hydraulic, Manual Adjust Single-Servo w/Park

ABS Components

Item	Part No.	Description
26	097-004-00	Sensor, Straight
27	024-204-00	Sensor Block
28	097-002-00	Sensor Clip
29	024-205-01	Tone Ring
ns	007-248-00	Tone Ring Screws

Hub & Drum

Item	Part No.	Description
23	008-415-02	Hub & Drum Assembly
ns	008-415-04	Hub & Drum Assembly - ABS

ns - not shown

Studs and Wheel Nuts

Item	Part No.	Description	Nut Torque
18*	006-109-00	5/8-18 90° Cone Nut	200 lbs.-ft
19*	033-052-01	Clamp Ring	
17	006-058-00	5/8-18 Flange Nut	300 lbs.-ft
13	007-115-00	5/8-18 Press-in Stud	

* Must use the 90° cone nut with the clamp ring. Alternate fastener is just the flange nut.

9K, 10K, #13G, #14T General Duty Two-Piece Hubs



9,000-10,000 GD CAPACITY

Before July 2009

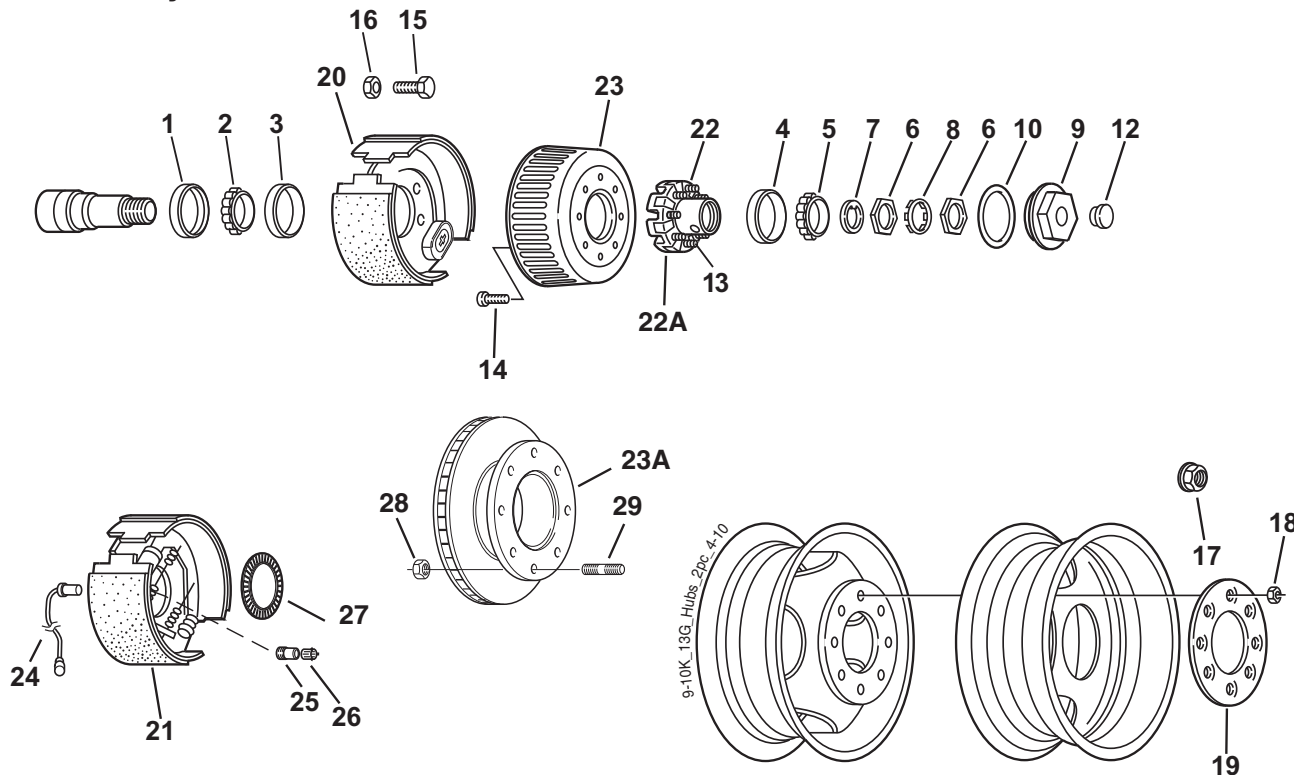

Standard Oil Lube Parts

Item	Part No.	Description
1	010-051-02	Oil Seal
2	031-019-02	387A Inner Bearing Cone
3	031-019-01	382A Inner Bearing Cup
4	031-030-01	25520 Outer Bearing Cup
5	031-030-02	25580 Outer Bearing Cone
6	006-096-00	Spindle Nut (2)
7	005-070-00	Spindle Washer
8	005-071-00	Tang Washer
9	021-036-00	Oil Cap
10	010-050-00	'O' Ring
12	046-032-00	Oil Cap Plug
13	007-115-00	5/8-18 Wheel Stud
14	007-245-00	Drum Mounting Screw
15	007-116-00	Brake Mounting Bolt
16	006-017-00	Brake Mounting Nut
ns	005-008-00	Lockwasher

Hub & Drum

Item	Part No.	Description
22	008-288-03	Oil Hub w/Cups and Studs
23	009-044-01	Drum - Machined
ns	009-044-03	Drum - for ABS
ns	008-288-05	Oil Hub and Drum w/Cups and Studs

Hub & Rotor Available on #13G Not Offered on D90, D100G, #14T

Item	Part No.	Description
22A	008-288-07	Oil Hub w/Cups and Studs
23A	070-006-01	Brake Rotor
28	006-046-00	Rotor Mounting Nut
29	025-014-00	Rotor Mounting Stud

12 1/4" x 3 3/8" Brakes

Item	Part No.	Description
20	K23-450-00/K23-451-00	LH/RH Electric, FSA
21	K23-410-00/K23-411-00	LH/RH Hydraulic, FSA, Duo-Servo
21	K23-210-00/K23-211-00	LH/RH Hydraulic, FSA, Du-Servo w/Park
ns	K23-412-00/K23-413-00	LH/RH Hydraulic, FSA, Single-Servo
ns	K23-234-00/K23-235-00	LH/RH Hydraulic, Manual Adjust Single-Servo w/Park

ABS Components

Item	Part No.	Description
24	097-004-00	Sensor, Straight
25	024-204-00	Sensor Block
26	097-002-00	Sensor Clip
27	024-203-00	Tone Ring

Studs and Wheel Nuts

Item	Part No.	Description	Nut Torque
18*	006-109-00	5/8-18 90° Cone Nut	200 lbs.-ft
19*	033-052-01	Clamp Ring	
17	006-058-00	5/8-18 Flange Nut	300 lbs.-ft
13	007-115-00	5/8-18 Press-in Stud	

ns - not shown

* Must use the 90° cone nut with the clamp ring. Alternate fastener is just the flange nut.

One-piece hub/drum is not interchangeable with the two-piece hub & drum.



Articulation Dimensions

Dimensions are for #14 bracket. Allow 3" bump clearance from full load.

Start Angle	Bracket Profile	No Load		Full Load		Shock Load	
		H	L	H	L	H	L
45° Down	High	7.68	4.24	5.74	5.54	4.74	5.83
32° Down	High	6.62	5.09	4.43	5.92	3.44	5.84
22.5° Down	High	5.74	5.54	3.44	6.00	2.40	5.91
10° Down	High	4.48	5.91	2.14	5.86	1.14	5.54
0°	High	3.44	6.00	1.14	5.54	0.22	5.06
10° Up	High	2.40	5.91	0.22	5.06	0.39	4.42
22.5° Up	High	1.14	5.54	-0.80	4.24	-1.47	3.44

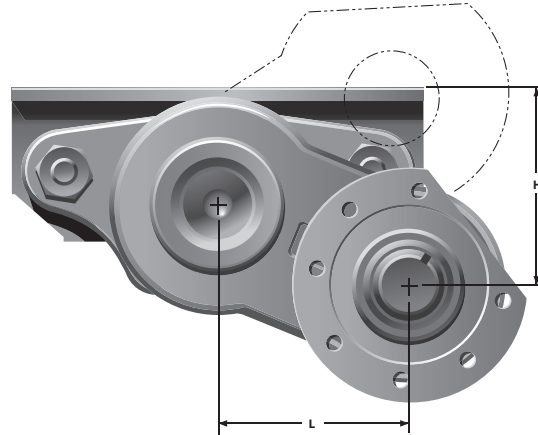

Note: Positive numbers in the H column indicate the spindle is BELOW the top of the bracket. Conversely, negative numbers are ABOVE the top of the bracket.

Overhang Per Side

Spindle	Min.	Brake
#14	12.75"	12¼" x 5"
#14T	9.89"	12¼" x 3⅜"
#14	9.19"	Disc

Note: One-piece hub/drum is not interchangeable with the two-piece hub & drum.



Full Load Dimensions

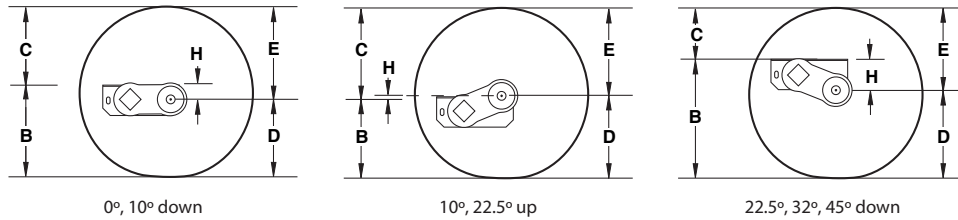

Start Angle

Tire	* **		45° Down			32° Down			22.5° Down			10° Down			0°			10° Up			22.5° Up		
	D	E	H	B	C	H	B	C	H	B	C	H	B	C	H	B	C	H	B	C	H	B	C
LT235/85R16	14.3	15.4	5.7	20.0	9.70	4.4	18.7	11.0	3.4	17.7	12.0	2.1	16.4	13.3	1.1	15.4	14.3	.2	14.5	15.2	-0.8	13.5	16.2
215/75R17.5	14.0	15.3	5.7	19.7	9.60	4.4	18.4	10.9	3.4	17.4	11.9	2.1	16.1	13.2	1.1	15.1	14.2	.2	14.2	15.1	-0.8	13.2	16.1
235/75R17.5	14.3	15.7	5.7	20.0	10.0	4.4	18.7	11.3	3.4	17.7	12.3	2.1	16.4	13.6	1.1	15.4	14.6	.2	14.5	15.5	-0.8	13.5	16.5
9R17.5HC	15.4	17.1	5.7	21.1	11.4	4.4	19.8	12.7	3.4	18.8	13.7	2.1	17.5	15.0	1.1	16.5	16.0	.2	15.6	16.9	-0.8	14.6	17.9
10R17.5HC	15.6	18.0	5.7	21.3	12.3	4.4	20.0	13.6	3.4	19.0	14.6	2.1	17.7	15.9	1.1	16.7	16.9	.2	15.8	17.8	-0.8	14.8	18.8

Columns D and E are dimensional examples only:

* D – Static Loaded Radius

** E – Inflated Radius

#14 Bracket Dimensions	
A	4.50
B	9.00
C	12.00
D	4.50
E	2.44
F	2.50
Bolt Size	¾" bolt
Tube Size	4.25

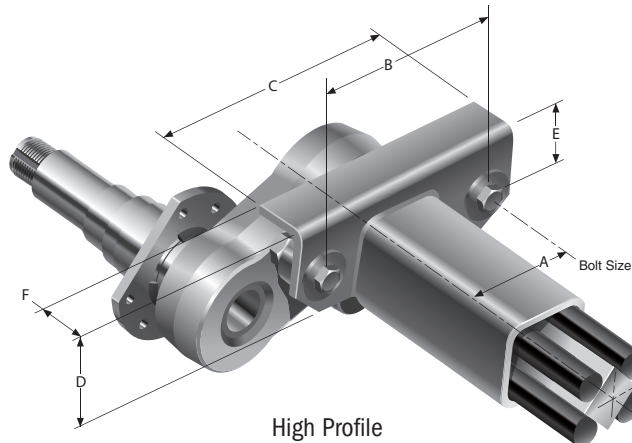

High Profile

10K, 12K, 15K, #13D, and #14 Hubs



10,000-15,000 CAPACITY

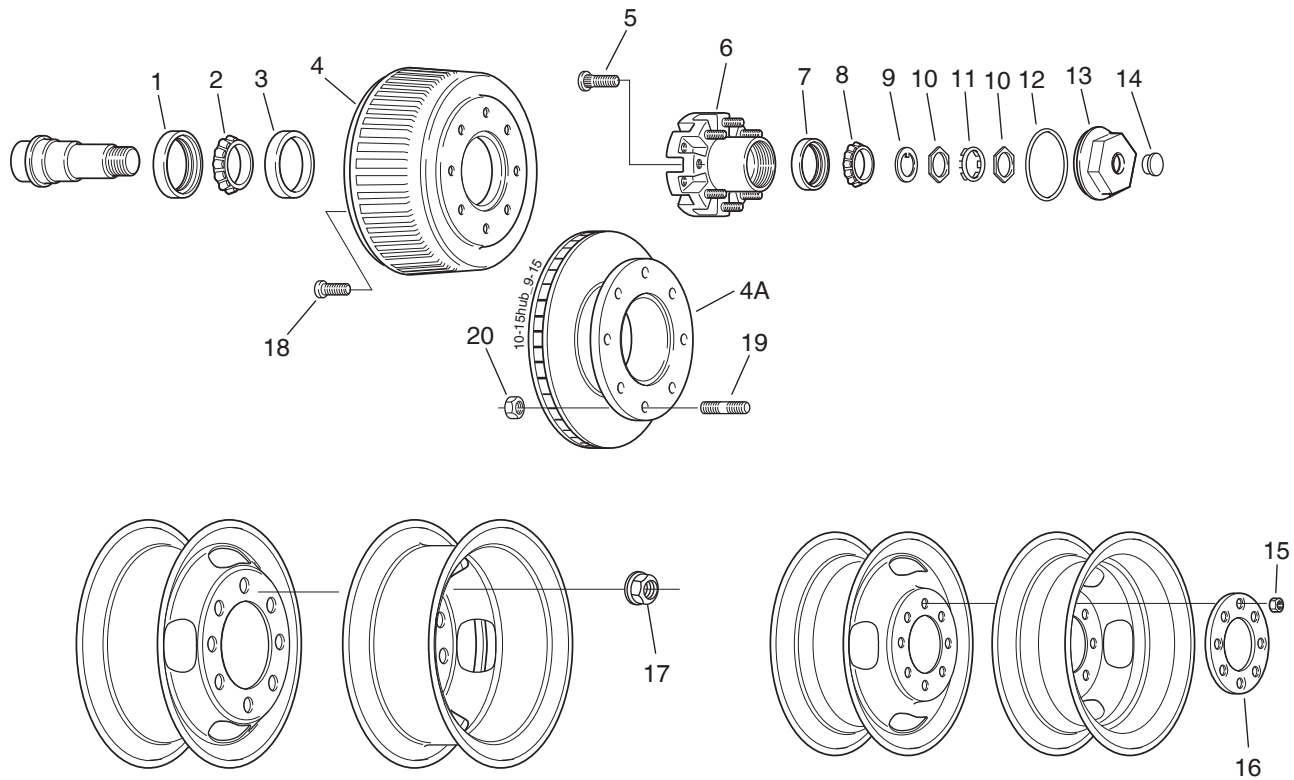

Item	Description	10K, #13D 8 on 6.50	10K, #13D Disc 8 on 6.50	12K Low-Profile 8 on 6.50	12K Hi-Profile 8 on 6.50	#14 Hi-Profile 8 on 6.50	#14 Disc 8 on 6.50	12K Disc 8 on 6.50	15K 8 on 275 mm
1	Unitized Oil Seal	010-056-00	010-056-00	010-056-00	010-056-00	010-056-00	010-056-00	010-056-00	010-056-00
2	Inner Bearing Cone	031-022-02 (395S)	031-022-02 (395S)	031-020-02 (3984)	031-020-02 (3984)	031-020-02 (3984)	031-020-02 (3984)	031-020-02 (3984)	031-020-02 (3984)
3	Inner Bearing Cup	031-022-01 (394A)	031-022-01 (394A)	031-020-01 (3920)	031-020-01 (3920)	031-020-01 (3920)	031-020-01 (3920)	031-020-01 (3920)	031-020-01 (3920)
4	Brake Drum	009-027-01	-	009-028-01	009-028-01	009-028-01	-	-	009-028-01
4	Brake Drum-ABS	009-027-03	-	009-028-05	009-028-05	009-028-05	-	-	009-028-05
4A	Brake Rotor	-	070-006-01	-	-	-	070-010-02	070-006-01	-
4A	Brake Rotor-ABS	-	070-006-02	-	-	-	-	070-006-02	-
5	Wheel Mounting Stud	007-115-00	007-115-00	007-115-00	007-115-00	007-115-00	007-115-00	007-115-00	007-194-00 (std) 007-195-00 (long)
6	Hubs w/Cups & Studs	008-214-05	008-214-06	008-216-08	008-214-08	008-422-03	008-422-04	008-214-10	008-401-05 (std stud) 008-401-06 (long stud)
7	Outer Bearing Cup	031-019-01 (382A)	031-019-01 (382A)	031-021-01 (28622)	031-021-01 (28622)	031-021-01 (28622)	031-021-01 (28622)	031-021-01 (28622)	031-021-01 (28622)
8	Outer Bearing Cone	031-019-02 (387A)	031-019-02 (387A)	031-021-02 (28682)	031-021-02 (28682)	031-021-02 (28682)	031-021-02 (28682)	031-021-02 (28682)	031-021-02 (28682)
9	Spindle Washer	005-060-00	005-060-00	005-060-00	005-060-00	005-060-00	005-060-00	005-060-00	005-060-00
10	Spindle Nut	006-084-00	006-084-00	006-084-00	006-084-00	006-084-00	006-084-00	006-084-00	006-084-00
11	Tang Washer	005-059-00	005-059-00	005-059-00	005-059-00	005-059-00	005-059-00	005-059-00	005-059-00
12	Oil Cap "O" Ring	010-050-00	010-050-00	010-050-00	010-050-00	010-050-00	010-050-00	010-050-00	010-050-00
13	Oil Cap	021-036-00	021-036-00	021-036-00	021-036-00	021-036-00	021-036-00	021-036-00	021-036-00
14	Oil Cap Plug	046-032-00	046-032-00	046-032-00	046-032-00	046-032-00	046-032-00	046-032-00	046-032-00
15	Wheel Nut	006-109-00	006-109-00	006-109-00	006-109-00	006-109-00	006-109-00	006-109-00	-
16	Wheel Clamp Ring	033-052-01	033-052-01	033-052-01	033-052-01	033-052-01	033-052-01	033-052-01	-
17	Flange Nut (swivel)	006-209-00	006-209-00	006-209-00	006-209-00	006-209-00	-	006-209-00	006-118-00
18	Drum Mounting Screw	007-244-00	-	007-244-00	007-244-00	007-245-00	-	-	007-244-00
19	Rotor Mounting Stud	-	025-014-00	-	-	-	-	025-014-00	-
20	Rotor Mounting Nut	-	006-046-00	-	-	-	-	006-046-00	-
21	Disc Mounting Screw (ns)	-	-	-	-	-	007-292-00	-	-

ns - not shown

Forward Self-Adjusting Electric Brake

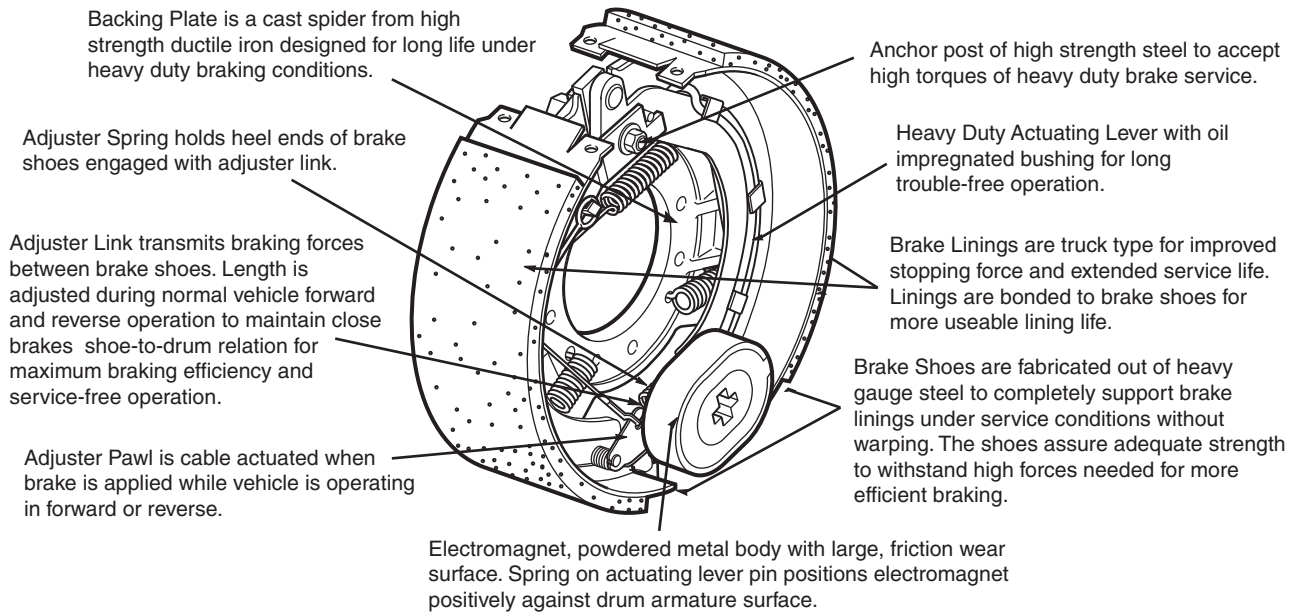

Electric Brakes

Size	Capacity	Part No. LH	Part No. RH
12 ¹ / ₄ " x 3 ³ / ₈ "	9K, 10K GD, #13G	K23-450-00	K23-451-00
12 ¹ / ₄ " x 4"	10K, #13D	K23-438-00	K23-439-00
12 ¹ / ₄ " x 5"	12K	K23-442-00	K23-443-00
12 ¹ / ₄ " x 5"	15K	K23-446-00	K23-447-00

Typical Electric Brake Wiring Diagram

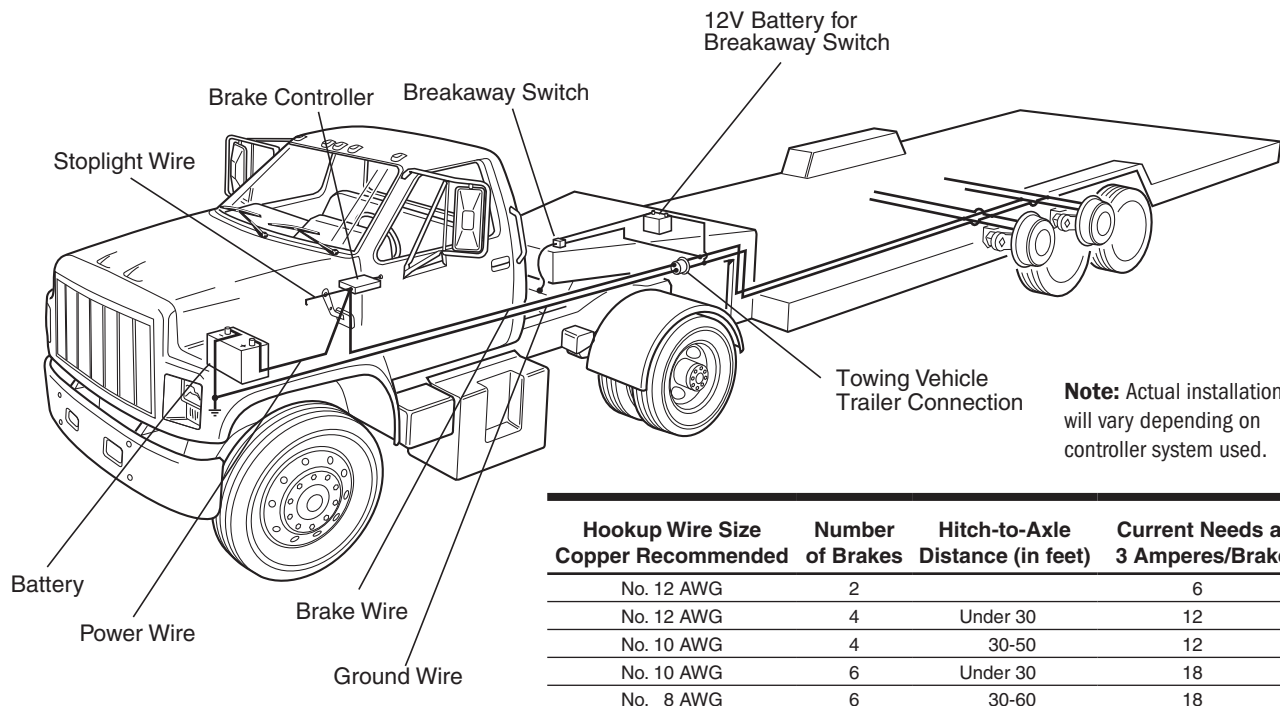

Electric Brake Parts - Cast Backing Plate



ELECTRIC BRAKES

After April 2000

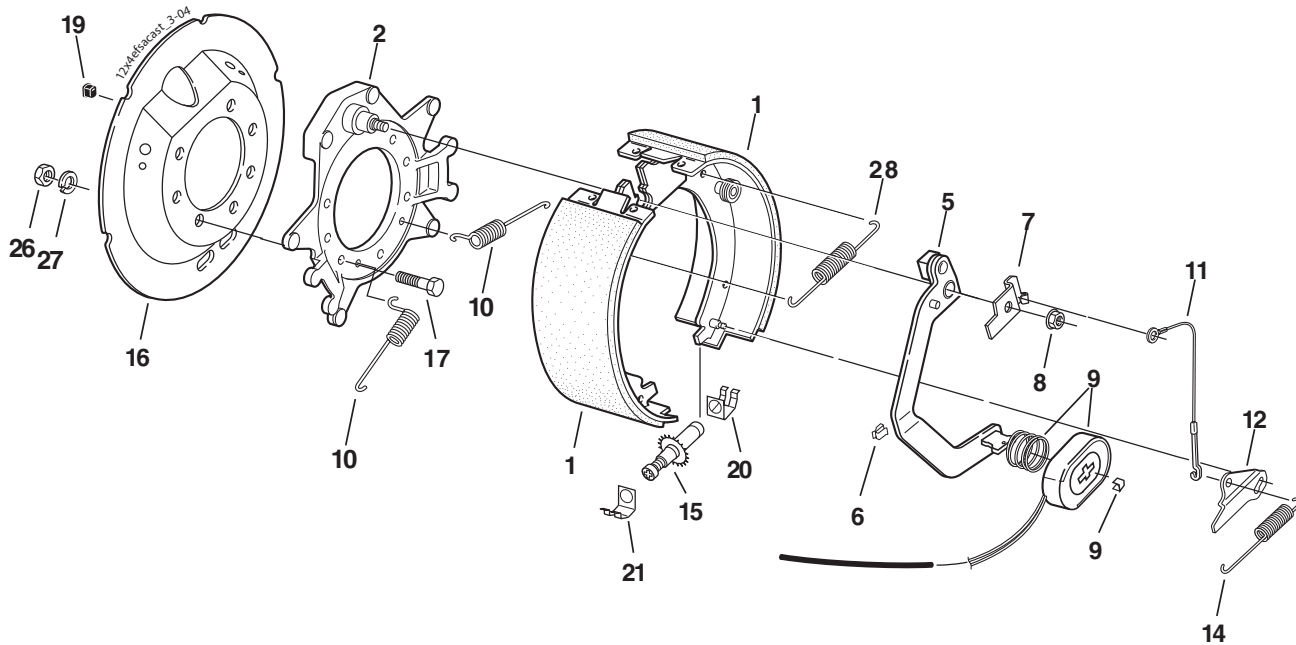

Item	Description	Qty Per Brake	12¼" x 3⅞"		12¼" x 4"		12¼" x 5"	
			9K, 10K GD, #13G Part No.	10K, #13D Part No.	12K Part No.	15K Part No.		
1	LH Shoe & Lining Kit Contains:	1	K71-499-00	K71-501-00	K71-503-00	K71-503-00		
	LH Primary	1	040-350-01	040-352-01	040-354-01	040-354-01		
	LH Secondary	1	040-351-02	040-353-02	040-355-02	040-355-02		
1	RH Shoe & Lining Kit Contains:	1	K71-498-00	K71-500-00	K71-502-00	K71-502-00		
	RH Primary	1	040-351-01	040-353-01	040-355-01	040-355-01		
	RH Secondary	1	040-350-02	040-352-02	040-354-02	040-354-02		
2	Backing Plate Assembly	1	036-120-02	036-120-02	036-120-02	036-120-02		
5	LH Actuator Arm Assembly	1	047-123-38	047-123-38	047-123-36	047-123-36		
	RH Actuator Arm Assembly	1	047-123-37	047-123-37	047-123-35	047-123-35		
6	Wire Clip	3	027-039-00	027-039-00	027-039-00	027-039-00		
7	LH Arm/Shoe Retainer	1	071-455-01	071-455-01	071-455-01	071-455-01		
	RH Arm/Shoe Retainer	1	071-455-02	071-455-02	071-455-02	071-455-02		
8	Flange Nut	1	006-092-01	006-092-01	006-092-01	006-092-01		
9	Magnet Kit Contains:	1	K71-378-00	K71-378-00	K71-378-00	K71-378-00		
	Magnet Retainer Clip	1	027-050-00	027-050-00	027-050-00	027-050-00		
	Magnet Assembly	1	042-131-00	042-131-00	042-131-00	042-131-00		
	Magnet Mounting Spring	1	046-117-00	046-117-00	046-117-00	046-117-00		
10	Centering Spring	2	046-136-00	046-136-00	046-136-00	046-136-00		
11	Adjuster Cable	1	071-462-00	071-462-00	071-462-00	071-462-00		
12	LH Adjuster Lever	1	071-464-00	071-464-00	071-464-00	071-464-00		
	RH Adjuster Lever	1	071-463-00	071-463-00	071-463-00	071-463-00		
14	Adjuster Spring	1	046-137-00	046-137-00	046-137-00	046-137-00		
15	LH Adjuster Assembly	1	048-019-00	048-019-00	048-019-00	048-019-00		
	RH Adjuster Assembly	1	048-020-00	048-020-00	048-020-00	048-020-00		
16	Dust Shield	1	036-115-21	036-115-22	036-115-23	036-115-23		
17	Brake Mounting Screw	7	007-116-00	007-116-00	007-116-00	007-116-00		
19	Wire Grommet	1	046-016-00	046-016-00	046-016-00	046-016-00		
20	Adjuster Clip (thread end)	1	046-132-00	046-132-00	046-132-00	046-132-00		
21	Adjuster Clip (barrel end)	1	046-133-00	046-133-00	046-133-00	046-133-00		
26	Brake Mounting Nut	7	006-017-00	006-017-00	006-017-00	006-017-00		
27	Brake Mounting Lockwasher	7	005-008-00	005-008-00	005-008-00	005-008-00		
28	Return Spring	1	046-119-00	046-119-00	046-119-00	046-119-00		

Electric Brake Parts - Stamped Backing Plate



Prior to April 2000
Service Parts Only

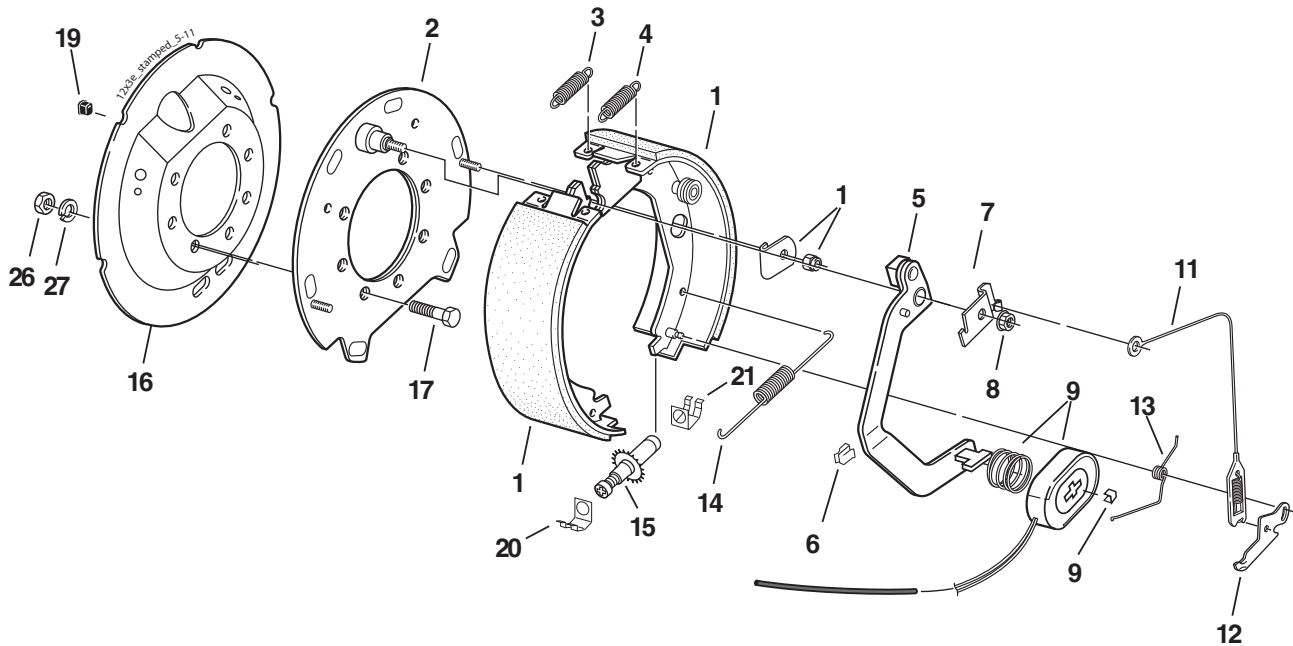

Item	Description	Qty Per Brake	12¼" x 3¾" 9K, 10K GD, #13G Part No.	12¼" x 4" 10K, #13D Part No.	12¼" x 5" 12K Part No.	12¼" x 5" 15K Part No.
1	LH Shoe & Lining Kit Contains:	1	K71-049-00	K71-051-00	K71-053-00	K71-053-00
	LH Primary	1	040-110-01	040-108-01	040-102-01	040-102-01
	LH Secondary	1	040-111-02	040-109-02	040-103-02	040-103-02
	Shoe Hold Down Washer	2	005-107-00	005-107-00	005-107-00	005-107-00
	Lock Nut	2	006-127-00	006-127-00	006-127-00	006-127-00
1	RH Shoe & Lining Kit Contains:	1	K71-050-00	K71-052-00	K71-054-00	K71-054-00
	RH Primary	1	040-111-01	040-109-01	040-103-01	040-103-01
	RH Secondary	1	040-110-02	040-108-02	040-102-02	040-102-02
	Shoe Hold Down Washer	2	005-107-00	005-107-00	005-107-00	005-107-00
	Lock Nut	2	006-127-00	006-127-00	006-127-00	006-127-00
2	Backing Plate Assembly (obsolete)	1	036-072-05	036-072-05	036-072-06	036-072-06
3	Shoe Return Spring (rear-black)	1	046-071-00	046-071-00	046-071-00	046-071-00
4	Shoe Return Spring (front-green)	1	046-083-00	046-083-00	046-083-00	046-083-00
5	LH Actuator Arm Assembly	1	047-123-38	047-123-38	047-123-36	047-123-36
	RH Actuator Arm Assembly	1	047-123-37	047-123-37	047-123-35	047-123-35
6	Wire Clip	3	027-039-00	027-039-00	027-039-00	027-039-00
7	LH Arm/Shoe Retainer	1	071-455-01	071-455-01	071-455-01	071-455-01
	RH Arm/Shoe Retainer	1	071-455-02	071-455-02	071-455-02	071-455-02
8	Flange Nut	1	006-092-01	006-092-01	006-092-01	006-092-01
9	Magnet Kit Contains:	1	K71-378-00	K71-378-00	K71-378-00	K71-378-00
	Magnet Retainer Clip	1	027-050-00	027-050-00	027-050-00	027-050-00
	Magnet Assembly	1	042-131-00	042-131-00	042-131-00	042-131-00
	Magnet Mounting Spring	1	046-117-00	046-117-00	046-117-00	046-117-00
11	Adjuster Cable	1	071-020-00	071-020-00	071-020-00	071-020-00
12	LH Adjuster Lever	1	071-019-01	071-019-01	071-019-01	071-019-01
	RH Adjuster Lever	1	071-019-02	071-019-02	071-019-02	071-019-02
13	LH Adjuster Lever Spring	1	046-073-00	046-073-00	046-073-00	046-073-00
	RH Adjuster Lever Spring	1	046-074-00	046-074-00	046-074-00	046-074-00
14	Adjuster Spring	1	046-072-00	046-072-00	046-072-00	046-072-00
15	LH Adjuster Assembly	1	048-009-00	048-009-00	048-009-00	048-009-00
	RH Adjuster Assembly	1	048-010-00	048-010-00	048-010-00	048-010-00
16	Dust Shield	1	036-115-21	036-115-22	036-115-23	036-115-23
17	Brake Mounting Screw	7	007-116-00	007-116-00	007-116-00	007-116-00
19	Wire Grommet	1	046-016-00	046-016-00	046-016-00	046-016-00
20	Adjuster Clip (thread end)	1	046-132-00	046-132-00	046-132-00	046-132-00
21	Adjuster Clip (barrel end)	1	046-133-00	046-133-00	046-133-00	046-133-00
26	Brake Mounting Nut	7	006-017-00	006-017-00	006-017-00	006-017-00
27	Brake Mounting Lockwasher	7	005-008-00	005-008-00	005-008-00	005-008-00

Forward Self-Adjusting Hydraulic Brake & System Diagram



HYDRAULIC BRAKES

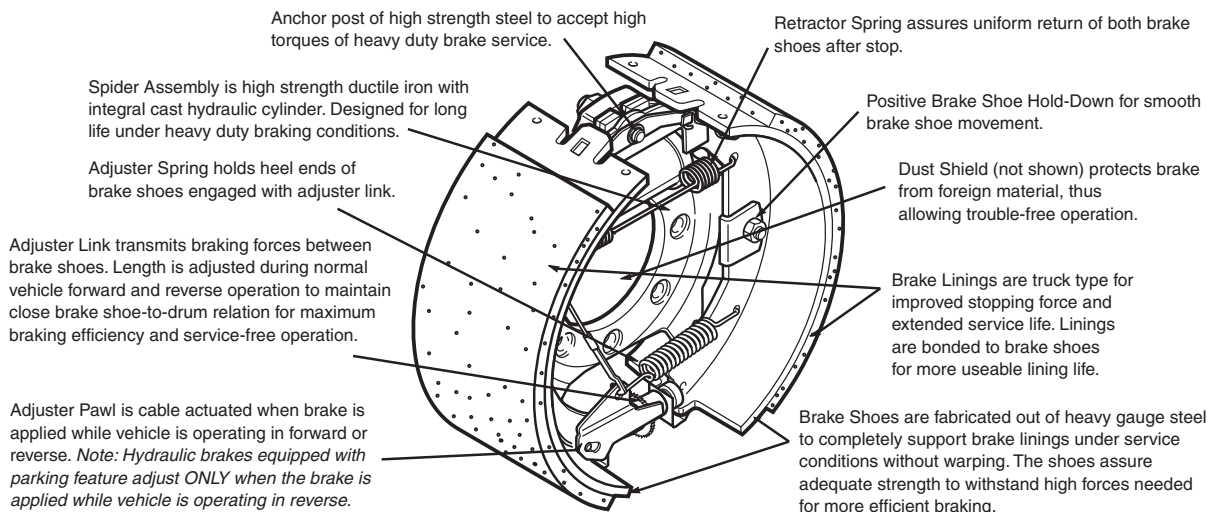

Hydraulic Brakes

Size	Capacity	Part No. LH	Part No. RH	
12¼" x 3⅝"	9K, 10K GD, #13G	K23-410-00	K23-411-00	Duo-Servo
12¼" x 3⅝"	9K, 10K GD, #13G	K23-412-00	K23-413-00	Uni-Servo
12¼" x 3⅝"	9K, 10K GD, #13G	K23-210-00	K23-211-00	Duo-Servo*
12¼" x 4"	10K, #13D	K23-404-00	K23-405-00	Duo-Servo
12¼" x 4"	10K, #13D	K23-414-00	K23-415-00	Uni-Servo
12¼" x 4"	10K, #13D	K23-168-00	K23-169-00	Duo-Servo*
12¼" x 4"	10K, #13D	K23-222-00	K23-223-00	Uni-Servo**
12¼" x 5"	12K	K23-408-00	K23-409-00	Duo-Servo
12¼" x 5"	12K	K23-416-00	K23-417-00	Uni-Servo
12¼" x 5"	12K	K23-165-00	K23-166-00	Duo-Servo*
12¼" x 5"	15K	K23-406-00	K23-407-00	Duo-Servo
12¼" x 5"	15K	K23-162-00	K23-163-00	Duo-Servo*

* Duo-Servo brake with park is equipped with a rear self-adjusting feature.

** Uni-Servo brake with park is equipped with a manual adjusting feature.

Hydraulic System Installation Suggestions

1. Use 3/16" steel tubing having 2000 PSI working pressure rating for all hardline connections between the actuator and take-off to axle. All tubing must have double flare connection at joints.
2. Anchor hydraulic tubing securely to frame and axle.
3. Use inverted flare fittings having 82° included angle.
4. Use D.O.T. high pressure hydraulic hose for flex connection(s) (frame to axle).

WARNING: It is the brake system installer's responsibility to insure compatibility between towing vehicles and trailer actuation systems. Various combinations of Air/Hydraulic, E/H, or Vacuum/Hydraulic and tow vehicle systems can allow normal working pressure to exceed 1000 PSI on drum brakes. Pressures in excess of 1000 PSI on drum brakes increase lining wear and can lead to component failure. Make certain your system has the correct peak pressure to activate brakes properly.

Dexter Axle E/H Units

Model E/H 1000 P/N K71-650-00 for Drum Brakes Only

Model E/H 1600 P/N K71-651-00 for Disc Brakes Only

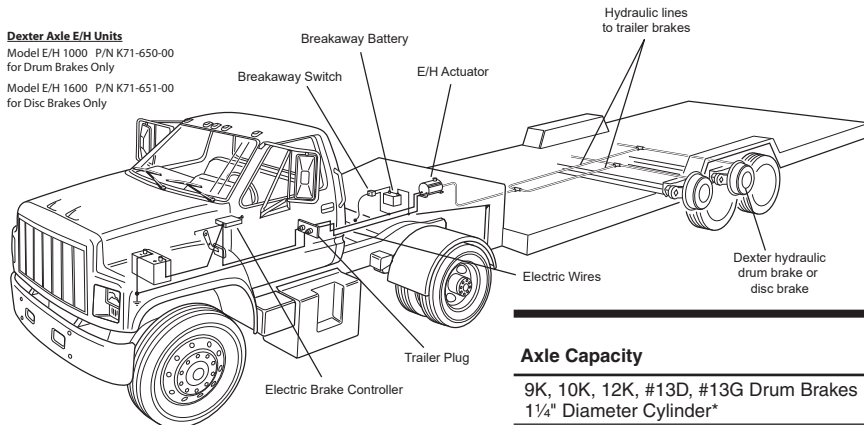

Axle Capacity	Maximum Operating Pressure (PSI)	Total Fluid Displacement Required per Axle
9K, 10K, 12K, #13D, #13G Drum Brakes 1¼" Diameter Cylinder*	1000	1.30 cu. in.
10K, 12K, #13D Disc Brakes 2½" Diameter Piston (Quantity 2)**	1600	.80 cu. in.
15K Drum Brakes 1⅜" Diameter cylinder*	1000	1.50 cu. in.

* Use 3/8-24 flare nut fitting on 3/16" tube or hose to connect to back of brake.

** Use 7/16-20 straight thread inlet to connect to brake.

Hydraulic Brake Parts

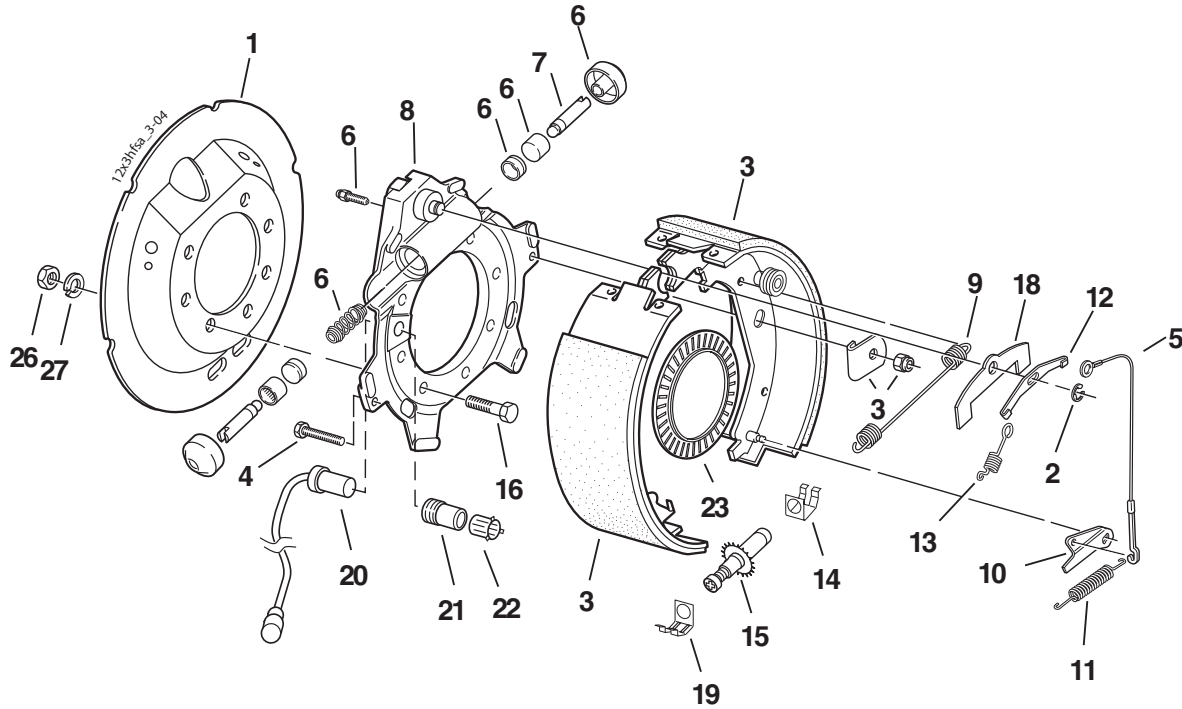

Item	Description	Qty Per Brake	12¼" x 3⅝" 9K, 10K GD, #13G Part No.	12¼" x 4" 10K, #13D Part No.	12¼" x 5" 12K Part No.	12¼" x 5" 15K Part No.
1	Dust Cover	1	036-115-21	036-115-22	036-115-23	036-115-23
2	Retainer	1	069-053-00	069-053-00	069-053-00	069-053-00
3	LH Shoe & Lining Kit Contains:	1	K71-165-00	K71-167-00	K71-169-00	K71-169-00
	LH Primary	1	040-199-01	040-197-01	040-195-01	040-195-01
	LH Secondary	1	040-199-02	040-197-02	040-195-02	040-195-02
	Hold Down Washer	2	005-107-00	005-107-00	005-107-00	005-107-00
	Hold Down Locknut	2	006-086-00	006-086-00	006-086-00	006-086-00
3	RH Shoe & Lining Kit Contains:	1	K71-166-00	K71-168-00	K71-170-00	K71-170-00
	RH Primary	1	040-200-01	040-198-01	040-196-01	040-196-01
	RH Secondary	1	040-200-02	040-198-02	040-196-02	040-196-02
	Hold Down Washer	2	005-107-00	005-107-00	005-107-00	005-107-00
	Hold Down Locknut	2	006-086-00	006-086-00	006-086-00	006-086-00
4	Show Hold Down Screw	2	007-113-00	007-113-00	007-113-00	007-113-00
5	Adjuster Cable	1	071-462-00	071-462-00	071-462-00	071-462-00
6	Wheel Cylinder Kit Contains:	1	K71-081-00	K71-081-00	K71-081-00	K71-082-00
	Cylinder Spring	1	046-128-00	046-128-00	046-128-00	046-129-00
	Cylinder Boot	2	054-032-00	054-032-00	054-032-00	054-032-00
	Cylinder Piston	2	054-038-00	054-038-00	054-038-00	054-030-00
	Cylinder Cup	2	054-086-00	054-086-00	054-086-00	054-087-00
	Bleeder Screw	2	054-035-00	054-035-00	054-035-00	054-035-00
7	Cylinder Push Rod	2	054-033-00	054-033-00	054-033-00	054-033-00
8	Spider Assembly	1	036-063-06	036-063-06	036-063-06	036-063-04
9	Retractor Spring	1	046-087-00	046-087-00	046-087-00	046-087-00
10	LH Adjuster Lever	1	071-464-00	071-464-00	071-464-00	071-464-00
	RH Adjuster Lever	1	071-463-00	071-463-00	071-463-00	071-463-00
11	LH Adjuster Lever Spring (blue)	1	046-135-00	046-135-00	046-135-00	046-135-00
	RH Adjuster Lever Spring (black)	1	046-134-00	046-134-00	046-134-00	046-134-00
12	Cable Attachment Bracket FSA	1	071-456-00	071-456-00	071-456-00	071-456-00
13	Extension Spring	1	046-131-01	046-131-01	046-131-01	046-131-01
14	Adjuster Clip (barrel end)	1	046-133-00	046-133-00	046-133-00	046-133-00
15	LH Adjuster Assembly	1	048-019-00	048-019-00	048-019-00	048-019-00
	RH Adjuster Assembly	1	048-020-00	048-020-00	048-020-00	048-020-00
16	Brake Mounting Bolt	7	007-116-00	007-116-00	007-116-00	007-116-00
18	Piston Stop	1	034-062-00	034-062-00	034-062-00	034-062-00
19	Adjuster Clip (thread end)	1	046-132-00	046-132-00	046-132-00	046-132-00
26	Brake Mounting Nut	7	006-017-00	006-017-00	006-017-00	006-017-00
27	Lockwasher	7	005-008-00	005-008-00	005-008-00	005-008-00
Optional ABS Parts:						
20	ABS Sensor (straight)	1	097-004-00	097-004-00	097-004-00	097-004-00
21	ABS Sensor Mounting Block	1	024-204-00	024-204-00	024-204-00	024-204-00
22	ABS Sensor Retaining Clip	1	097-002-00	097-002-00	097-002-00	097-002-00
23	ABS Tone Ring in Drum	1	024-203-00	024-203-00	024-203-00	024-203-00

10K, 12K, #13G, #13D and #14 Hydraulic Disc Brake



DISC BRAKES

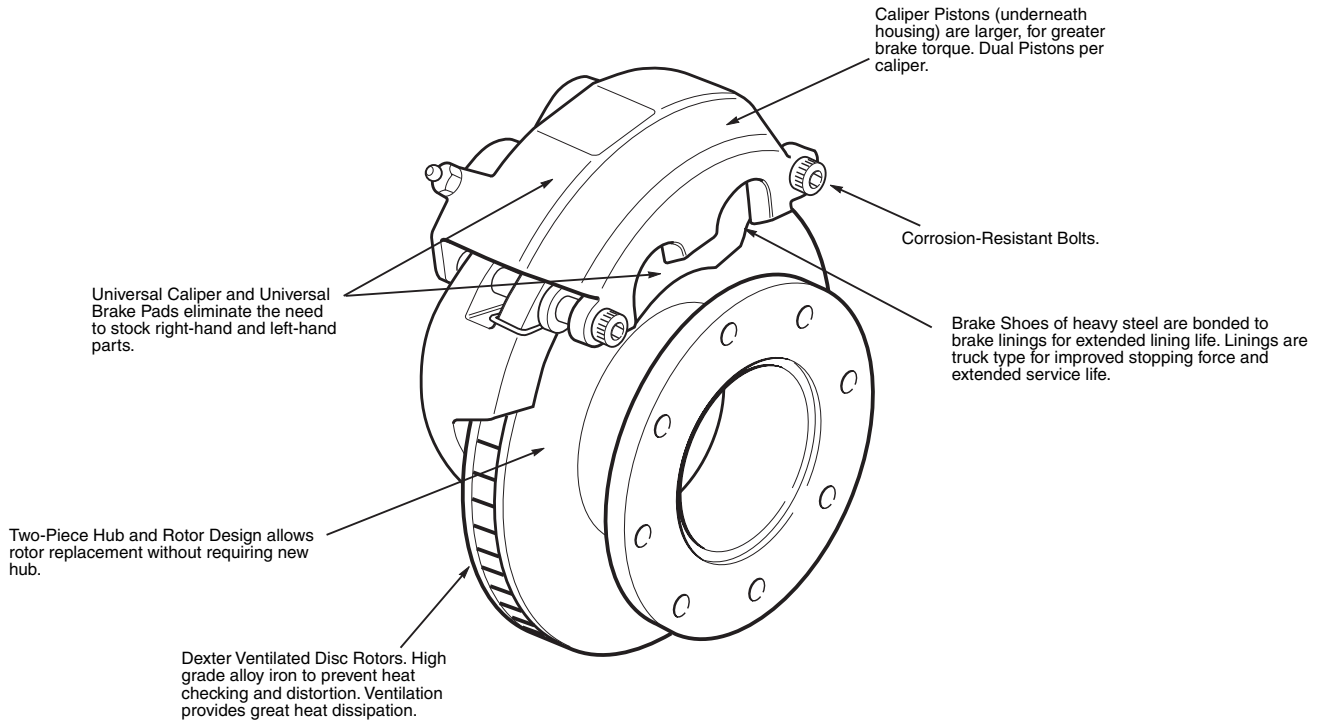

Hydraulic Disc Brake Parts

Item	Description	Qty/ Brake	10K, 12K	#13G, #13D	#14
1	Anchor Yoke Assembly (includes 6 of item #6)	1	090-002-02	090-002-02	090-011-02
2	Caliper Assembly (includes items #6, 3, 9, 10)	1	089-002-02	089-002-02	089-002-02
3	Caliper Piston	2	054-066-00	054-066-00	054-066-00
12	Shoulder Screw 5/8 x 5	2	007-186-00	007-186-00	007-186-00
13	Hex Screw 7/16-20 x 1.75	7	007-116-00	007-116-00	007-116-00
14	Flange Nut	8	006-046-00	006-046-00	-
15	Hex Nut 7/16-20	7	006-017-00	006-017-00	006-017-00
16	Rotor Mounting Stud	8	025-014-00	025-014-00	-
17	ABS Sensor (straight)	1	097-004-00	-	-
19	ABS Sensor Retaining Clip	1	097-002-00	-	-
20	ABS Tone Ring	1	024-203-00	-	-
21	Lock Washer	7	005-008-00	005-008-00	-
Caliper Repair Kit Contains:		1	K71-181-00	K71-181-00	K71-181-00
6	"O" Ring	4	010-062-00	010-062-00	010-062-00
7	Bleeder Screw	1	054-069-00	054-069-00	054-069-00
9	Caliper Seal	2	054-067-00	054-067-00	054-067-00
10	Dust Boot	2	054-068-00	054-068-00	054-068-00
Disc Brake Replacement Pad Kit Contains:		1	K71-180-00	K71-180-00	K71-180-00
4	Brake Pad	4	091-003-00	091-003-00	091-003-00
5	Anti-Rattle Spring	4	046-105-00	046-105-00	046-105-00
6	"O" Ring	20	010-062-00	010-062-00	010-062-00
8	Hex Locknut	4	006-125-00	006-228-00	006-125-00
11	Installation Tool	1	071-182-00	071-182-00	071-182-00

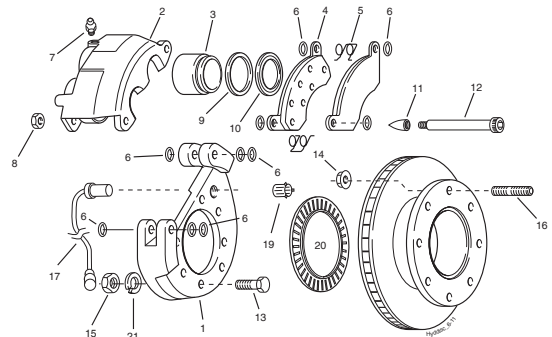

Recommend hose with banjo fitting.
 7/16-20 threaded hole for fitting.
 ABS not available on #13G or #13D.

Dexter "S" Cam Brake

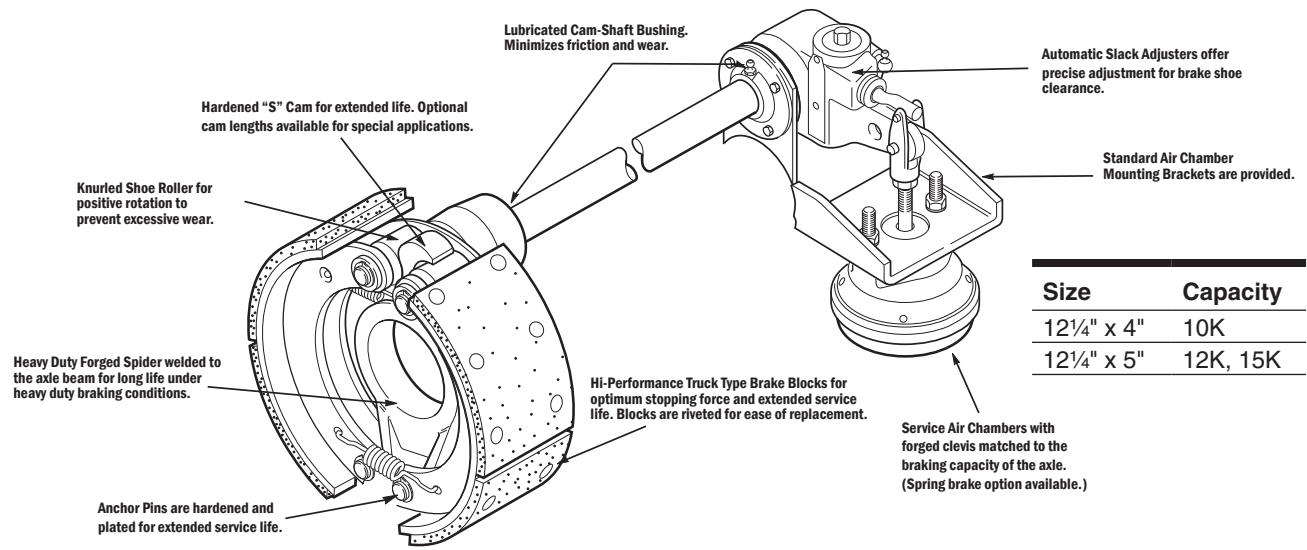

Small "S" Head Hi-Rise 28 Spline

Part No.		A	B	C
LH	RH			
034-188-00	034-189-00	21.125	2.219	For 1.50 dia. shaft +
034-188-01	034-189-01	16.375	2.219	For 1.50 dia. shaft +
034-188-03	034-189-03	22.312	2.219	For 1.50 dia. shaft +
034-188-04	034-189-04	20.312	2.219	For 1.50 dia. shaft
034-188-05	034-189-05	23.375	2.219	For 1.50 dia. shaft
034-188-06	034-189-06	30.000	2.219	For 1.50 dia. shaft
034-188-07	034-189-07	29.000	2.219	For 1.50 dia. shaft
034-188-08	034-189-08	19.500	2.219	For 1.50 dia. shaft
034-188-09	034-189-09	26.500	2.219	For 1.50 dia. shaft
034-188-10	034-189-10	7.437	4.980	For 1.50 dia. shaft
034-188-11	034-189-11	24.625	2.219	For 1.50 dia. shaft

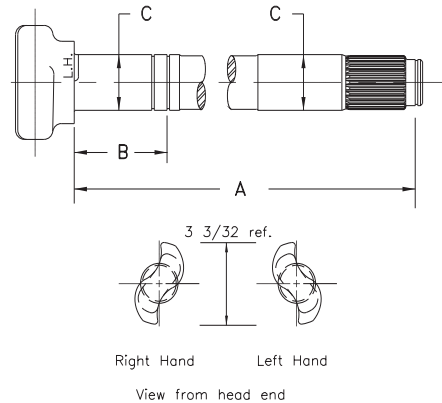

+ No extra charge for these lengths.

Typical Air Brake System Diagram

- 1 - Air Compressor
 - 2 - Tow Vehicle Reservoir
 - 3 - Actuation Valve
 - 4 - Control Gladhand
 - 5 - Supply Gladhand
 - 6 - Trailer Reservoir
 - 7 - Relay Valve
 - 8 - Air Chambers
- Control Plumbing
 ——— Supply Plumbing

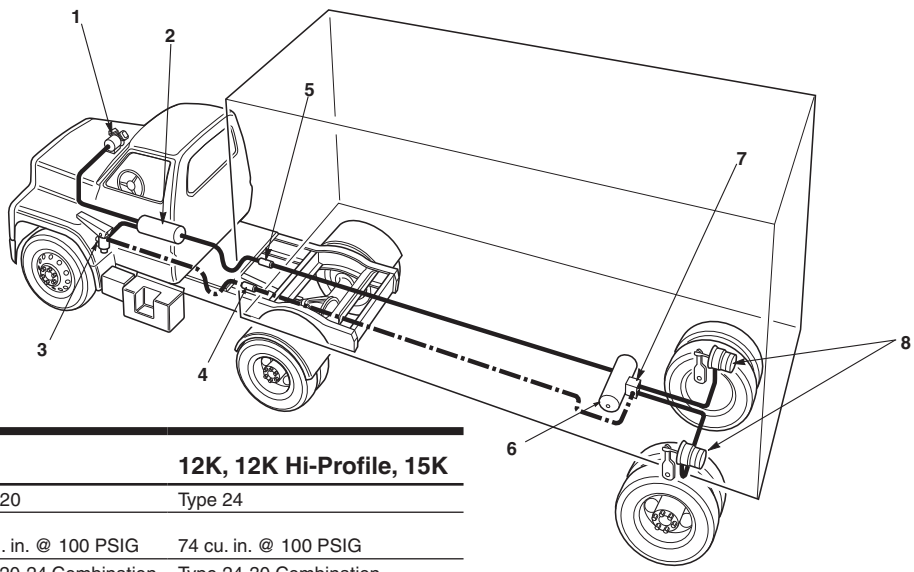

	10K	12K, 12K Hi-Profile, 15K
Air chamber Size	Type 20	Type 24
Air Chamber Full Stroke Volume	64 cu. in. @ 100 PSIG	74 cu. in. @ 100 PSIG
Spring Brake Type	Type 20-24 Combination	Type 24-30 Combination
Spring Brake Volume (caged)	96 cu. in. @ 100 PSIG	120 cu. in. @ 100 PSIG

Air Brake Parts – “PQ” Style



AIR BRAKES

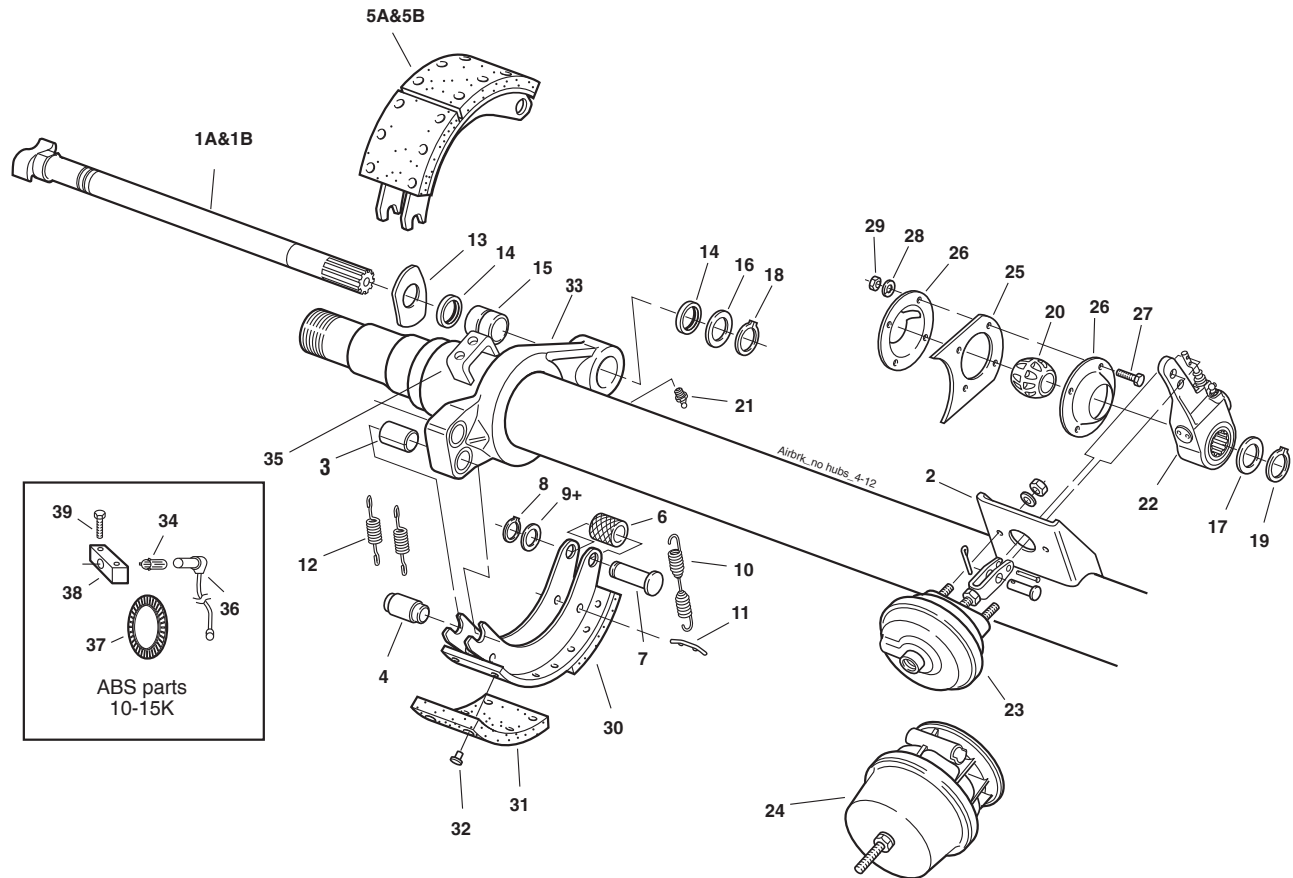

Item	Description	Qty Per Brake	12¼" x 4" 10K Part No.	12¼" x 5" 12K, 15K Part No.
1A	Camshaft LH*	1	034-188-xx	034-188-xx
1B	Camshaft RH*	1	034-189-xx	034-189-xx
2	Air Chamber Bracket	1	034-048-00	034-048-00
5	Shoe & Lining Assembly	2	040-321-01	040-322-01
5A	Shoe & Roller Assembly RH	1	040-321-03	040-322-03
5B	Shoe & Roller Assembly LH	1	040-321-02	040-322-02
Camshaft Repair Kit Contains:				
13	"D" Washer, Camshaft	1	005-074-00	005-074-00
14	Grease Seal	2	010-052-00	010-052-00
15	Camshaft Bushing	1	014-056-00	014-056-00
16	Washer-Camshaft Spider End	1	005-075-00	005-075-00
17	Camshaft Washer-28 Spline	1	005-134-00	005-134-00
18	Retainer-Camshaf	1	069-020-00	069-020-00
19	Retainer-Camshaft End	1	069-078-00	069-078-00
20	Camshaft Support Bushing	1	014-058-00	014-058-00
21	Grease Fitting	1	061-006-00	061-006-00
ns	Instruction Sheet	1	059-663-00	059-663-00
22	Automatic Slack Adjuster-28 Spline	1	055-040-99	055-040-99
22	Manual Slack Adjuster - 28 Spline	1	055-039-00	055-039-00
23	Air Chamber w/Hardware	1	034-260-00	034-059-00
24	Air Chamber w/Spring Brake	1	034-261-00	034-060-00
25	Plate - Camshaft Support Bracket	1	034-031-00	034-031-00
26	Plate, Bushing Retainer	2	034-032-00	034-032-00
27	Bolt, Retainer Plate	4	007-139-00	007-139-00
28	Lock Washer	4	005-079-00	005-079-00
29	Nut	4	006-099-00	006-099-00
33	Brake Spider	1	036-113-02	036-113-02

* For camshaft with part no. xx, see page 23.

Item	Description	Qty Per Brake	12¼" x 4" 10K Part No.	12¼" x 5" 12K, 15K Part No.
Brake Shoe Repair Kit Contains:				
3	Bushing-Spider Anchor Pin	2	014-068-00	014-068-00
4	Anchor Pin	2	056-017-00	056-017-00
6	Roller	1	014-057-00	014-057-00
7	Roller Pin	2	056-010-00	056-010-00
8	Roller Pin Retainer	2	069-018-00	069-018-00
9	Roller Pin Spacer	2	005-076-00+	not used
10	Retractor Spring	1	046-092-00	046-092-00
11	Retainer Pin	2	056-018-00	056-018-00
12	Shoe Keeper Spring	2	046-097-00	046-097-00
ns	Instruction Sheet	1	059-553-00	059-553-00
Brake Block Kit Contains:				
31	Brake Block Anchor	2	041-052-01	041-053-01
30	Brake Block Cam	2	041-052-02	041-053-02
32	Rivet	24	022-018-00	022-048-00
ABS Components:				
34	ABS Sensor Retaining Clip	1	097-002-00	097-002-00
35	ABS Lower Sensor Mounting Block	1	024-101-00	024-101-00
36	ABS Sensor 90°	1	097-003-00	097-003-00
37	ABS Tone Ring in Drum	1	024-203-00	024-203-00
38	ABS Upper Sensor Mounting Block	1	024-101-01	024-101-01
39	Mounting Screw Upper Block	2	007-237-00	007-237-00

ns - not shown

+ 005-076-00 is required for 10K shoes with ¼" shoe web thickness.

Not required for ⅝" shoe web thickness. Used only on 12¼" x 4" shoes with ¼" webs.

Dexter Axle Suspension System

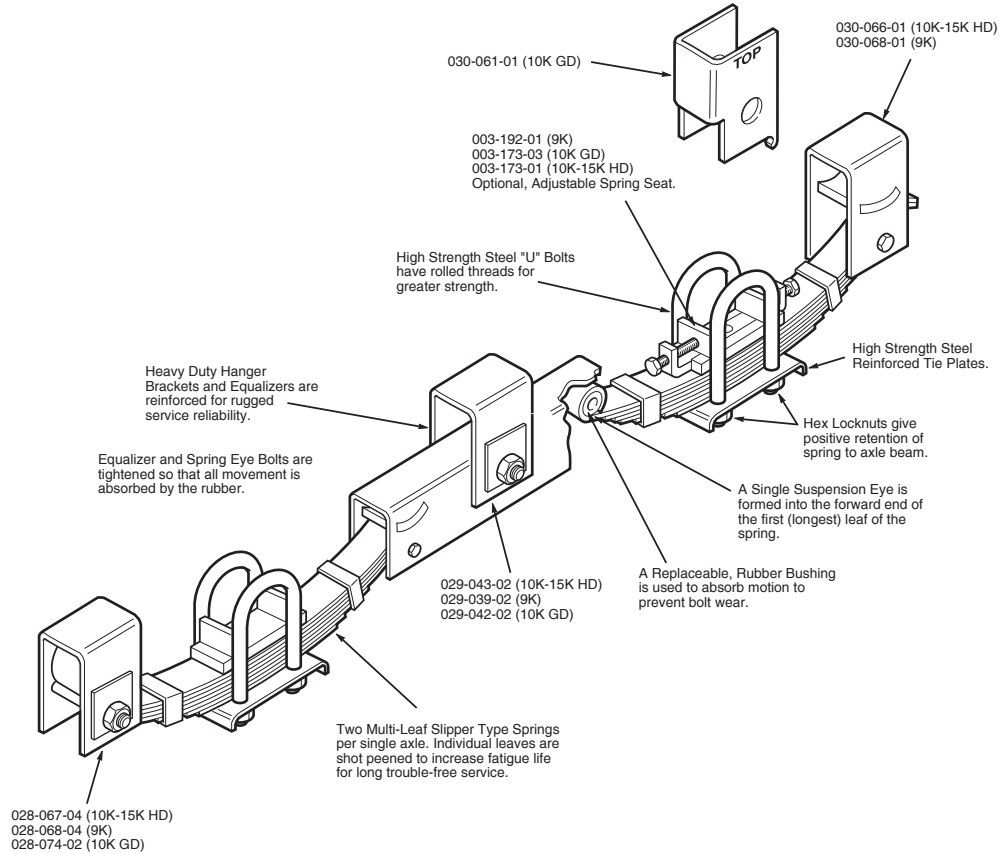

Cross Frame Hanger Reinforcement

CROSS FRAME REINFORCEMENT BETWEEN SPRING AND EQUALIZER HANGER BRACKETS ASSURES FULL LOAD CARRYING CAPABILITY OF THE AXLE MOUNTED STRUCTURE.

STANDARD THREE INCH STRUCTURAL CHANNEL IS SUGGESTED FOR REINFORCEMENT MEMBERS.

WELDS SHALL BE AS INDICATED.

RECOMMENDED HANGER WELDING PROCEDURE

WELD AROUND CORNER AS SHOWN

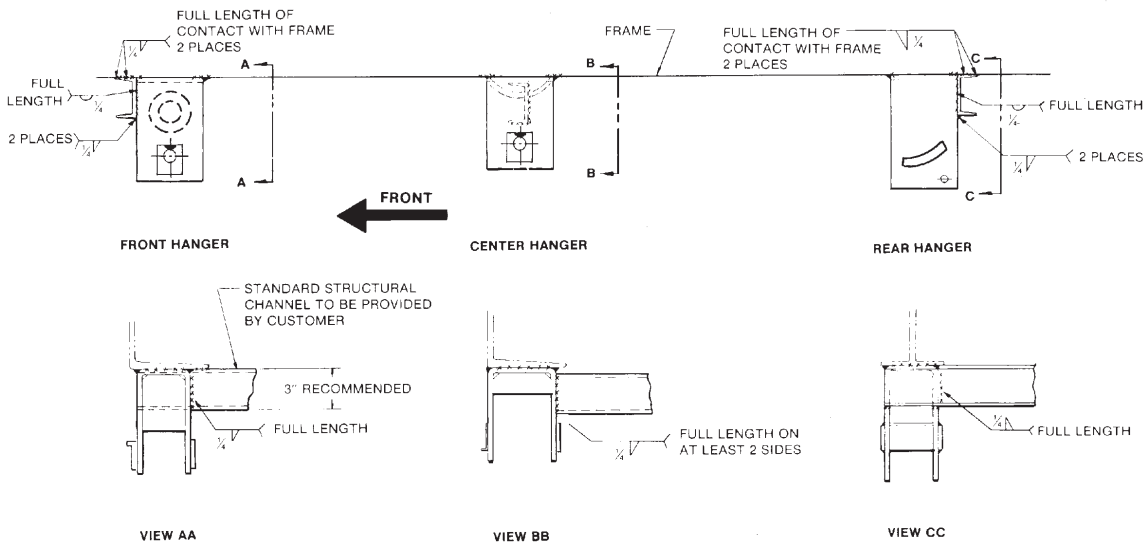
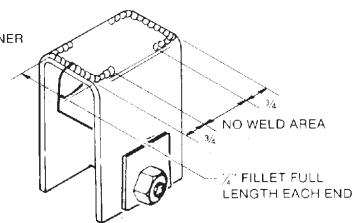

Kits for 2" Wide Springs



SINGLE SLIPPER SUSPENSIONS

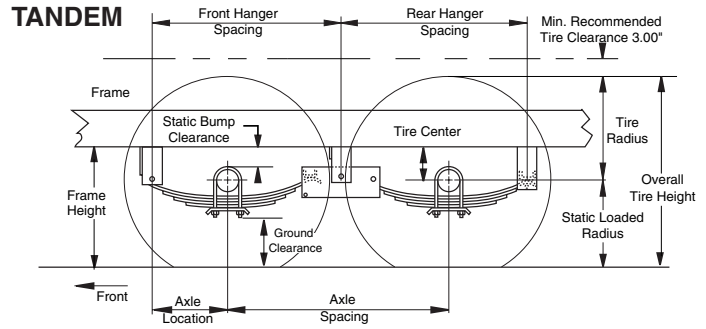
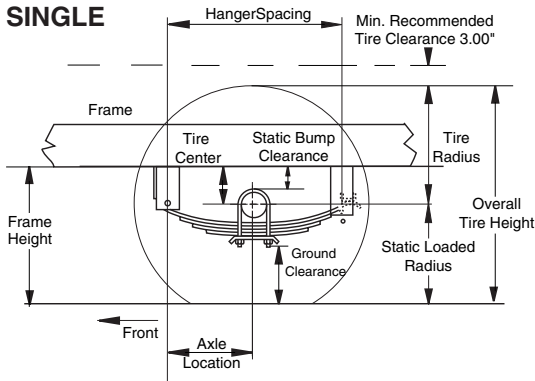

9K Single Axle HAP-105-00

Part No.	Qty	Description
028-068-04	2	Front Hanger
030-068-01	2	Rear Hanger
007-181-00	2	Spring Eye Bolt
007-007-00	2	Keeper Bolt
006-038-00	2	Locknut
006-011-00	2	Locknut
059-203-00	1	Instruction Sheet

9K Tandem Axle

	HAP-205-01	HAP-205-02	HAP-205-03
Front Hanger Spacing	32.4	34.6	37.7
Rear Hanger Spacing	32.9	35.0	38.1
Static Bump Clearance	2.3	2.3	2.3
Tire Center	4.9	4.9	4.9
Axle Location	13.7	13.7	13.7
Front Axle Spacing	38.0	42.3	48.5

9K Single Axle HAP-105-00

Front Hanger Spacing	26.9
Static Bump Clearance	2.6
Tire Center	5.2
Axle Location	13.7

9K 38" Multi-Axle Conversion Kit HAP-205-01

Part No.	Qty	Description
029-039-04	2	Center Hanger
013-117-03	2	Equalizer
007-181-00	2	Spring Eye Bolt
007-007-00	2	Keeper Bolt
007-182-00	2	Equalizer Bolt
006-038-00	2	Locknut
006-011-00	2	Locknut
006-112-00	2	Locknut
059-203-00	1	Instruction Sheet

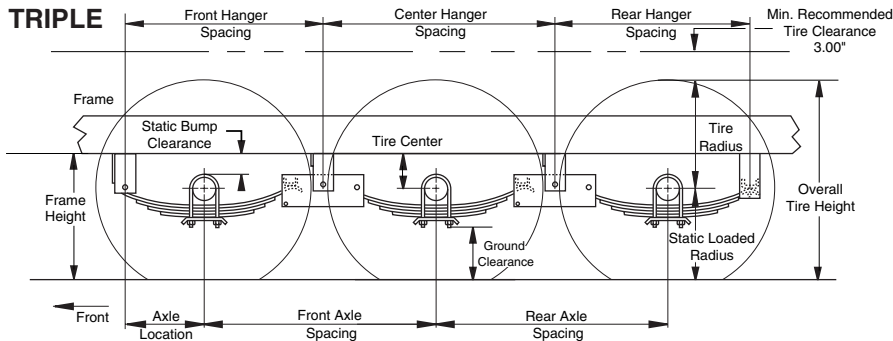

9K 42.25" Multi-Axle Conversion Kit HAP-205-02

Part No.	Qty	Description
029-039-04	2	Center Hanger
013-118-03	2	Equalizer
007-181-00	2	Spring Eye Bolt
007-007-00	2	Keeper Bolt
007-182-00	2	Equalizer Bolt
006-038-00	2	Locknut
006-011-00	2	Locknut
006-112-00	2	Locknut
059-203-00	1	Instruction Sheet

9K 38" Triple Axle

	HAP-205-01	HAP-205-02	HAP-205-03
Front Hanger Spacing	32.4	34.6	37.7
Center Hanger Spacing	38.0	42.3	48.5
Rear Hanger Spacing	32.9	35.0	38.1
Static Bump Clearance	2.3	2.3	2.3
Tire Center	4.9	4.9	4.9
Axle Location	13.7	13.7	13.7
Front Axle Spacing	38.0	42.3	48.5
Rear Axle Spacing	38.0	42.3	48.5

9K 48.5" Multi-Axle Conversion Kit HAP-205-03

Part No.	Qty	Description
029-039-04	2	Center Hanger
013-119-03	2	Equalizer
007-181-00	2	Spring Eye Bolt
007-007-00	2	Keeper Bolt
007-182-00	2	Equalizer Bolt
006-038-00	2	Locknut
006-011-00	2	Locknut
006-112-00	2	Locknut
059-203-00	1	Instruction Sheet

9K Axle Assemblies

	38"	42.25"	48.50"
For single axle assemblies use (1) HAP-105-00			
Tandem	(1) HAP-105-00 (1) HAP-205-01	(1) HAP-105-00 (1) HAP-205-02	(1) HAP-105-00 (1) HAP-205-03
Triple	(1) HAP-105-00 (2) HAP-205-01	(1) HAP-105-00 (2) HAP-205-02	(1) HAP-105-00 (2) HAP-205-03

All dimensions are for underslung spring orientation only.

Kits for 2½" Wide Springs ¾" Spring Eye Bolts

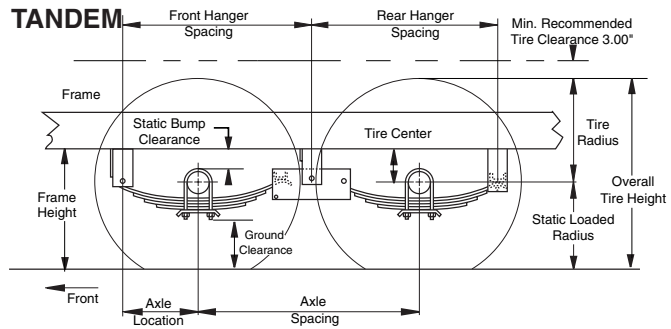
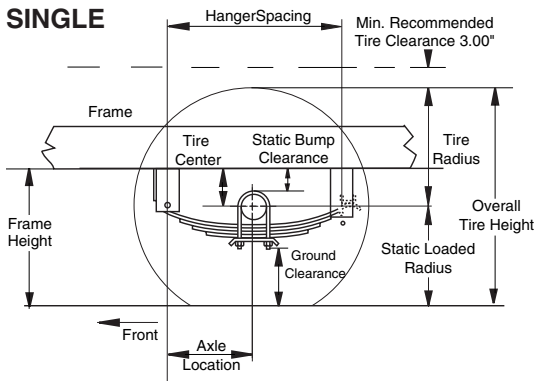

10K GD Single Axle HAP-158-00

Part No.	Qty	Description
028-074-02	2	Hanger
030-061-01	2	Rear Hanger
007-264-00	2	Spring Eye Bolt
006-113-00	2	Locknut
059-203-00	1	Instruction Sheet

10K GD Single Axle HAP-158-00

Front Hanger Spacing	27.4
Static Bump Clearance	1.9
Tire Center	5.0
Axle Location	14.0

10K GD Tandem Axle

HAP-258-01 HAP-258-02 HAP-258-03

Front Hanger Spacing	33.0	35.1	38.3
Rear Hanger Spacing	32.4	34.6	37.7
Static Bump Clearance	1.7	1.7	1.7
Tire Center	4.8	4.8	4.8
Axle Location	14.0	14.0	14.0
Front Axle Spacing	38.0	42.3	48.5

10K GD 38" Multi-Axle Conversion Kit HAP-258-01

Part No.	Qty	Description
006-112-00	2	Locknut
006-113-00	2	Locknut
007-264-00	2	Spring Eye Bolt
007-169-00	2	Equalizer Bolt
013-139-03	2	Equalizer
029-042-02	2	Center Hanger
059-203-00	1	Instruction Sheet

10K GD 42.25" Multi-Axle Conversion Kit HAP-258-02

Part No.	Qty	Description
006-112-00	2	Locknut
006-113-00	2	Locknut
007-264-00	2	Spring Eye Bolt
007-169-00	2	Equalizer Bolt
013-140-03	2	Equalizer
029-042-02	2	Center Hanger
059-203-00	1	Instruction Sheet

10K GD 48.5" Multi-Axle Conversion Kit HAP-258-03

Part No.	Qty	Description
006-112-00	2	Locknut
006-113-00	2	Locknut
007-264-00	2	Spring Eye Bolt
007-169-00	2	Equalizer Bolt
013-141-03	2	Equalizer
029-042-02	2	Center Hanger
059-203-00	1	Instruction Sheet

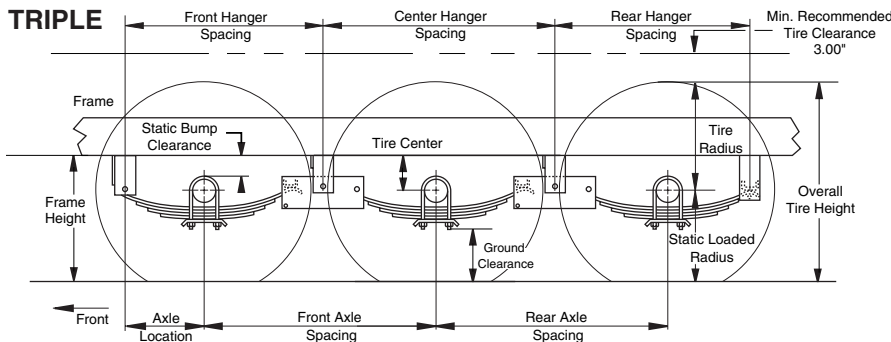

10K GD Triple Axle HAP-258-01 HAP-258-02 HAP-258-03

Front Hanger Spacing	33.0	35.1	38.3
Center Hanger Spacing	38.0	42.3	48.5
Rear Hanger Spacing	32.4	34.6	37.7
Static Bump Clearance	1.7	1.7	1.7
Tire Center	4.8	4.8	4.8
Axle Location	14.0	14.0	14.0
Front Axle Spacing	38.0	42.3	48.5
Rear Axle Spacing	38.0	42.3	48.5

10K GD Axle Assemblies

38" 42.25" 48.50"

	For single axle assemblies use (1) HAP-158-00		
Tandem	(1) HAP-158-00	(1) HAP-158-00	(1) HAP-158-00
	(1) HAP-258-01	(1) HAP-258-02	(1) HAP-258-03
Triple	(1) HAP-158-00	(1) HAP-158-00	(1) HAP-158-00
	(2) HAP-258-01	(2) HAP-258-02	(2) HAP-258-03

All dimensions are for underslung spring orientation only.

Kits for 3" Wide Springs



SINGLE SLIPPER SUSPENSIONS

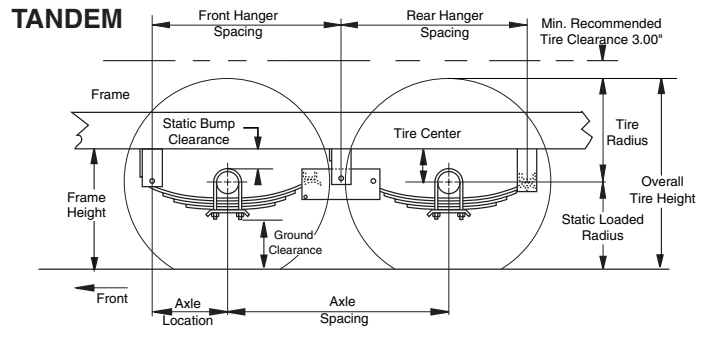
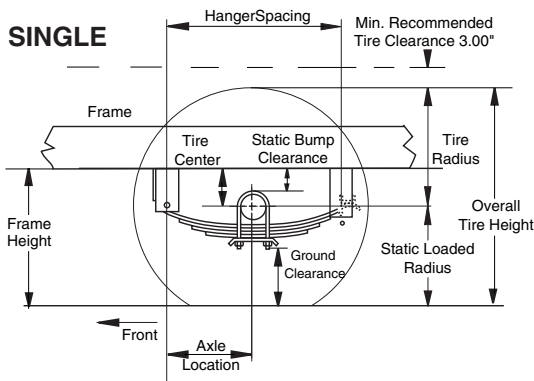

10-15K Single Axle HAP-103-00

Part No.	Qty	Description
028-067-04	2	Front Hanger
030-066-01	2	Rear Hanger
007-169-00	2	Spring Eye Bolt
007-095-00	2	Keeper Bolt
006-046-00	2	Locknut
006-112-00	2	Locknut
059-203-00	1	Instruction Sheet

10-15K Single Axle HAP-103-00

Front Hanger Spacing	27.4
Static Bump Clearance	2.9
Tire Center	6.0
Axle Location	14.0

10-15K Tandem Axle

HAP-203-01 HAP-203-02 HAP-203-03

	HAP-203-01	HAP-203-02	HAP-203-03
Front Hanger Spacing	33.0	35.1	38.3
Rear Hanger Spacing	32.4	34.6	37.7
Static Bump Clearance	2.2	2.2	2.2
Tire Center	5.3	5.3	5.3
Axle Location	14.0	14.0	14.0
Front Axle Spacing	38.0	42.3	48.5

10-15K 38" Multi-Axle Conversion Kit HAP-203-01

Part No.	Qty	Description
029-043-02	2	Center Hanger
013-107-07	2	Equalizer
007-169-00	2	Spring Eye Bolt
007-095-00	2	Keeper Bolt
007-170-00	2	Equalizer Bolt
006-046-00	2	Locknut
006-072-00	2	Locknut
006-112-00	2	Locknut
059-203-00	1	Instruction Sheet

10-15K 42.25" Multi-Axle Conversion Kit HAP-203-02

Part No.	Qty	Description
029-043-02	2	Center Hanger
013-108-03	2	Equalizer
007-169-00	2	Spring Eye Bolt
007-095-00	2	Keeper Bolt
007-170-00	2	Equalizer Bolt
006-046-00	2	Locknut
006-072-00	2	Locknut
006-112-00	2	Locknut
059-203-00	1	Instruction Sheet

10-15K 48.5" Multi-Axle Conversion Kit HAP-203-03

Part No.	Qty	Description
029-043-02	2	Center Hanger
013-109-03	2	Equalizer
007-169-00	2	Spring Eye Bolt
007-095-00	2	Keeper Bolt
007-170-00	2	Equalizer Bolt
006-046-00	2	Locknut
006-072-00	2	Locknut
006-112-00	2	Locknut
059-203-00	1	Instruction Sheet

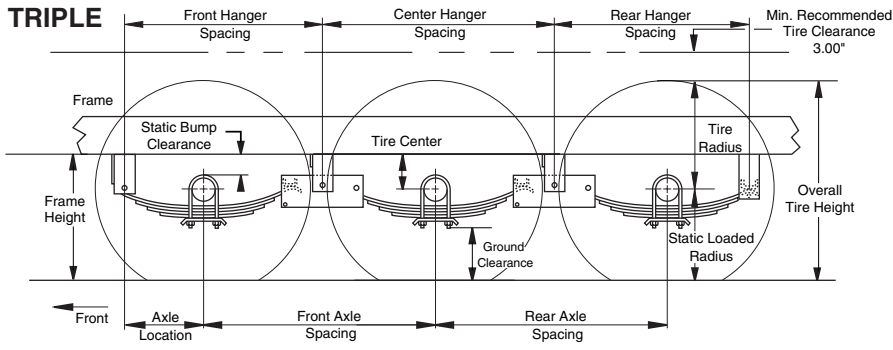

10-15K Triple Axle HAP-203-01 HAP-203-02 HAP-203-03

	HAP-203-01	HAP-203-02	HAP-203-03
Front Hanger Spacing	33.0	35.1	38.3
Center Hanger Spacing	38.0	42.3	48.5
Rear Hanger Spacing	32.4	34.6	37.7
Static Bump Clearance	2.0	2.0	2.0
Tire Center	5.1	5.1	5.1
Axle Location	14.0	14.0	14.0
Front Axle Spacing	38.0	42.3	48.5
Rear Axle Spacing	38.0	42.3	48.5

10-15K Axle Assemblies

38" 42.25" 48.50"

For single axle assemblies use (1) HAP-103-00			
Tandem	(1) HAP-103-00	(1) HAP-103-00	(1) HAP-103-00
	(1) HAP-203-01	(1) HAP-203-02	(1) HAP-203-03
Triple	(1) HAP-103-00	(1) HAP-103-00	(1) HAP-103-00
	(2) HAP-203-01	(2) HAP-203-02	(2) HAP-203-03

All dimensions are for underslung spring orientation only.

HDSS Underslung



SINGLE

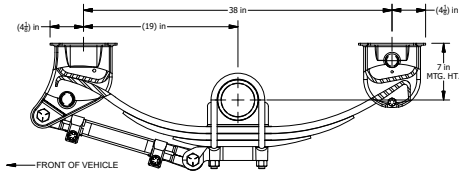

TANDEM

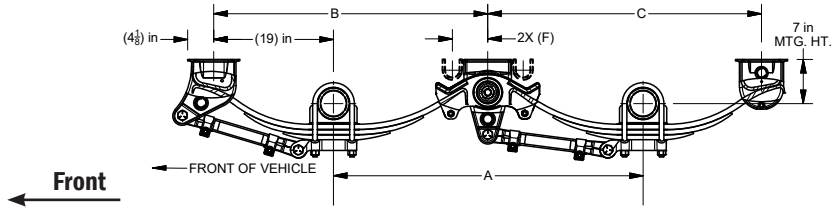

Axle Spacing	A	B	C	F
49 in	49 3/16 in	43 1/2 in	43 1/2 in	N/A
54 in	54 7/32 in	46 1/32 in	46 7/32 in	8 3/8 in
60 in	60 7/32 in	49 1/32 in	49 7/32 in	11 15/32 in

TRIPLE

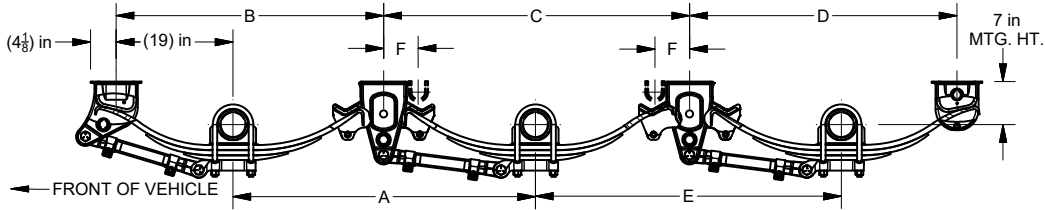

Axle Spacing	A	B	C	D	E	F
49 in	49 3/16 in	43 1/2 in	49 3/4 in	43 1/2 in	49 3/4 in	N/A
54 in	54 7/32 in	46 1/32 in	54 3/4 in	46 7/32 in	54 3/4 in	8 3/8 in
60 in	60 7/32 in	49 1/32 in	60 3/4 in	49 7/32 in	60 3/4 in	11 15/32 in

10-25K Single Axle Kit Contents

Part No.	Qty	Description
028-082-05	2	Front Hanger
030-075-05	2	Rear Hanger
062-010-10	1	Track Rod Bushed Adj 19.25
062-011-10	1	Track Rod Bushed Fixed 19.25
007-169-00	4	Track Rod Bolt 1-8 x 5.50 UNC
006-278-00	4	Track Rod Locknut 1-8 UNC
033-091-00	2	Keeper Bolt Sleeve
007-294-00	2	Spring Keeper Bolt 5/8-18 x 4.50 UNF
006-126-00	2	Keeper Bolt Locknut 5/8-18 UNF
059-918-00	1	Instruction Sheet

10-25K Multi Axle Kit Contents

Part No.	Qty	Description	Axle Spacing
029-044-10	2	Center Hanger and EQ Assembly HAP-261-01	49"
062-010-10	1	Track Rod Bushed Adj 19.25	49"
062-011-10	1	Track Rod Bushed Fixed 19.25	49"
029-049-10	2	Center Hanger and EQ Assembly HAP-162-01	54"
062-010-54	1	Track Rod Bushed Adj 21.75	54"
062-011-54	1	Track Rod Bushed Fixed 21.75	54"
029-049-20	2	Center Hanger and EQ Assembly HAP-163-01	60"
062-010-60	1	Track Rod Bushed Adj. 24.75	60"
062-011-60	1	Track Rod Bushed Fixed 24.75	60"
007-169-00	4	Track Rod Bolt 1-8 x 5.50 UNC	-
006-278-00	4	Track Rod Locknut 1-8 UNC	-
033-091-00	4	Keeper Bolt Sleeve	-
007-294-00	4	Spring Keeper Bolt 5/8-18 x 4.50 UNF	-
006-126-00	4	Keeper Bolt Locknut 5/8-18 UNF	-
059-918-00	1	Instruction Sheet	-

Suspension Kits

Order appropriate number of HAP kits for a complete suspension

HDSS Underslung		
	49"	54"
	HAP-161-01	HAP-162-01
Qty for Single	1	n/a
Qty for Tandem	1	1
Qty for Triple	1	2
	HAP-161-01	HAP-162-01
Qty for Single	1	n/a
Qty for Tandem	1	1
Qty for Triple	1	2
	HAP-161-01	HAP-163-01
Qty for Single	1	n/a
Qty for Tandem	1	1
Qty for Triple	1	2

OPTIONAL KITS - Per Axle

HAP-166-00 Bump Stops (One Pair)

SINGLE

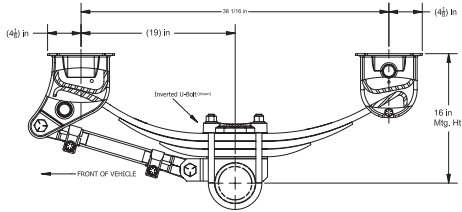

TANDEM

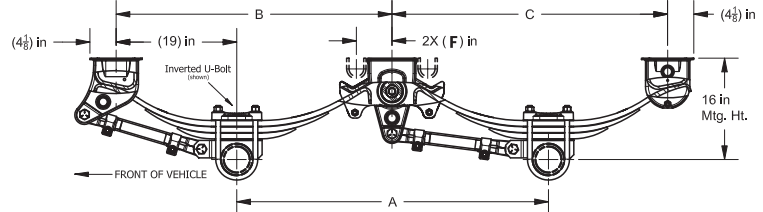

Axle Spacing	A	B	C	F
49 in	49 in	43 1/2 in	43 1/2 in	5 5/8 in
54 in	54 3/16 in	46 1/16 in	46 in	8 3/8 in
60 in	60 3/16 in	49 1/16 in	49 in	11 7/16 in

TRIPLE

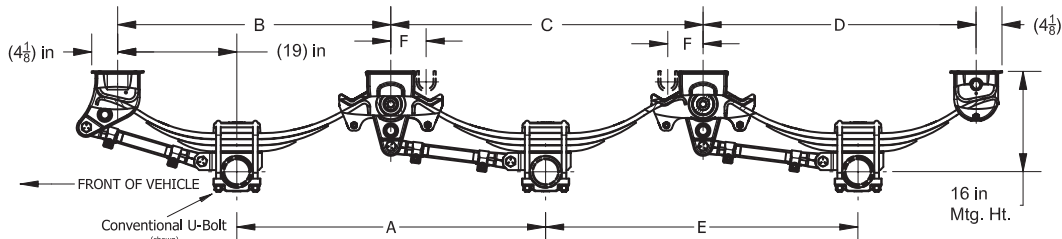

Axle Spacing	A	B	C	D	E	F
49 in	49 3/16 in	43 1/2 in	49 3/4 in	43 1/2 in	49 3/4 in	5 5/8 in
54 in	54 3/16 in	46 1/16 in	54 3/4 in	46 in	54 3/4 in	8 3/8 in
60 in	60 3/16 in	49 1/16 in	60 3/4 in	49 in	60 3/4 in	11 7/16 in

10-25K Single Axle Kit Contents

Part No.	Qty	Description
028-082-05	2	Front Hanger
030-075-05	2	Rear Hanger
062-010-10	1	Track Rod Bushed Adj 19.25
062-011-10	1	Track Rod Bushed Fixed 19.25
007-169-00	4	Track Rod Bolt 1-8 x 5.50 UNC
006-278-00	4	Track Rod Locknut 1-8 UNC
033-091-00	2	Keeper Bolt Sleeve
007-294-00	2	Spring Keeper Bolt 5/8-18 x 4.50 UNF
006-126-00	2	Keeper Bolt Locknut 5/8-18 UNF
059-918-00	1	Instruction Sheet

10-25K Multi Axle Kit Contents

Part No.	Qty	Description	Axle Spacing
029-044-10	2	Center Hanger and EQ Assembly HAP-261-01	49"
062-010-10	1	Track Rod Bushed Adj 19.25	49"
062-011-10	1	Track Rod Bushed Fixed 19.25	49"
029-049-10	2	Center Hanger and EQ Assembly HAP-162-01	54"
062-010-54	1	Track Rod Bushed Adj 21.75	54"
062-011-54	1	Track Rod Bushed Fixed 21.75	54"
029-049-20	2	Center Hanger and EQ Assembly HAP-163-01	60"
062-010-60	1	Track Rod Bushed Adj. 24.75	60"
062-011-60	1	Track Rod Bushed Fixed 24.75	60"
007-169-00	4	Track Rod Bolt 1-8 x 5.50 UNC	-
006-278-00	4	Track Rod Locknut 1-8 UNC	-
033-091-00	4	Keeper Bolt Sleeve	-
007-294-00	4	Spring Keeper Bolt 5/8-18 x 4.50 UNF	-
006-126-00	4	Keeper Bolt Locknut 5/8-18 UNF	-
059-918-00	1	Instruction Sheet	-

Suspension Kits

Order appropriate number of HAP kits for a complete suspension

HDSS Overslung			
	49"	HAP-161-01	HAP-261-01
Qty for Single	1	n/a	
Qty for Tandem	1	1	
Qty for Triple	1	2	
	54"	HAP-161-01	HAP-162-01
Qty for Single	1	n/a	
Qty for Tandem	1	1	
Qty for Triple	1	2	
	60"	HAP-161-01	HAP-163-01
Qty for Single	1	n/a	
Qty for Tandem	1	1	
Qty for Triple	1	2	

OPTIONAL KITS - Per Axle

HAP-164-01 Attaching Parts Kit - Inverted U-Bolts (Spring Seats, Tie Plates, and Attaching Hardware)
HAP-165-01 Attaching Parts Kit - Conventional U-Bolts (Spring Seats, Tie Plates, and Attaching Hardware)
HAP-166-00 Bump Stops (One Pair)

AIRFLEX® for 10,000 Lb. Axles



AIRFLEX® SUSPENSION

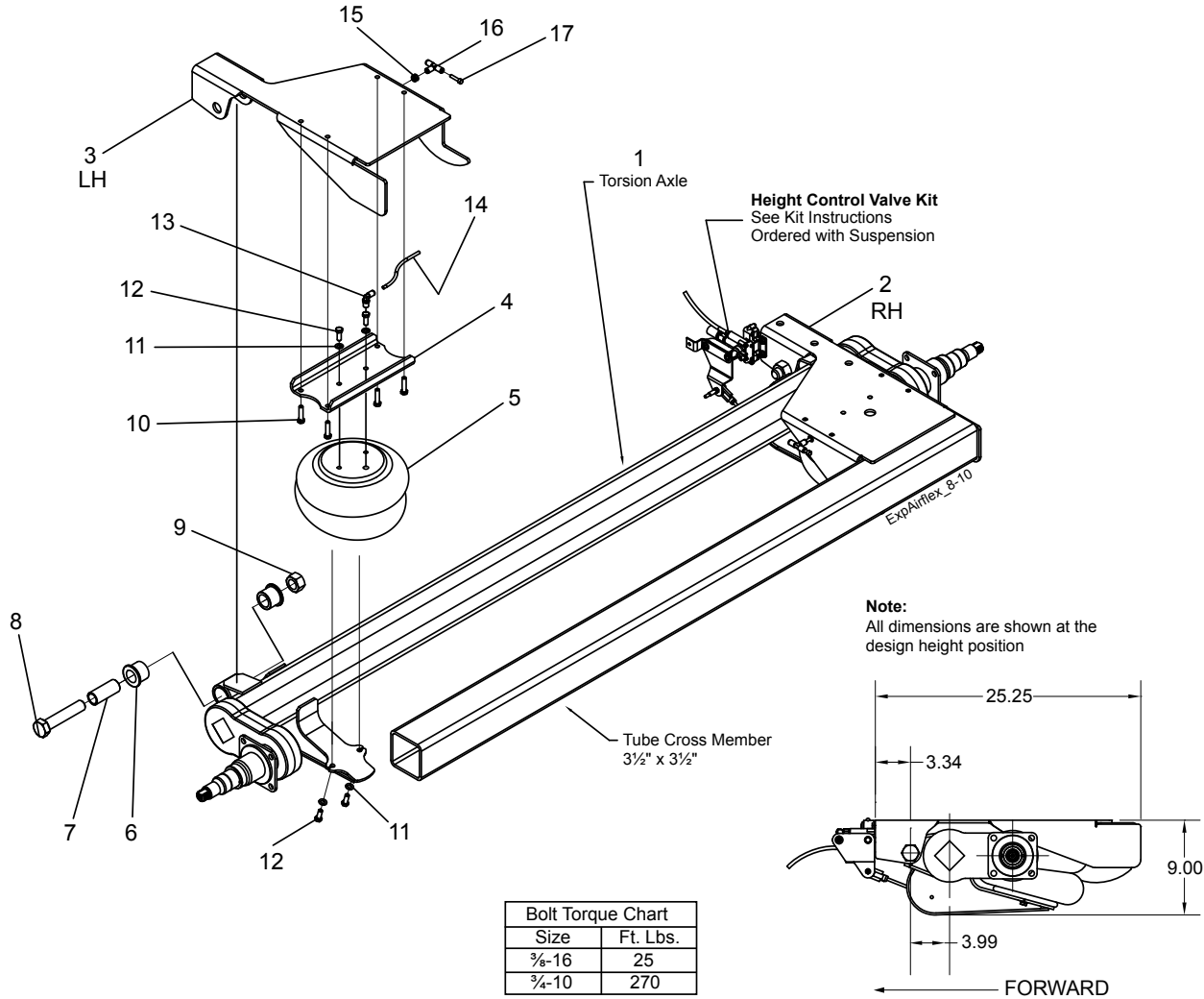

AIRFLEX® Suspension Components 10,000#

Item	Part No.	Qty/Axle	Description
1	n/a	1	Torsion Axle with Suspension Brackets
2	003-327-00	1	RH Frame Bracket
3	003-326-00	1	LH Frame Bracket
4	003-323-00	2	Channel, Air Spring Support
5	W01-358-6947	2	Firestone Air Spring
6	K71-734-00	2	Pivot Bushing Replacement Kit
7	n/a	2	3/4-10 UNC x 4.5" LG HHCS
8	n/a	2	3/4-10 UNC Stover Lock Nut
9	n/a	8	3/8-16 UNC x 1.5" LG HHCS
10	n/a	8	3/8 Regular Split Lock Washer
11	n/a	8	3/8-16 UNC x 1" LG HHCS
12	n/a	2	1/4 NPTM x 1/4 T 90° Elbow, Swivel
13	n/a	2	1/4 x 6.25" LG Nylon Tube
14	n/a	2	Grommet
15	n/a	2	1/4 T Union Tee
16	n/a	2	1/4 T Plug

n/a - not available

10,000 Lb. Heavy Duty Wheel & Hub Assembly



WHEEL & HUB ASSEMBLY

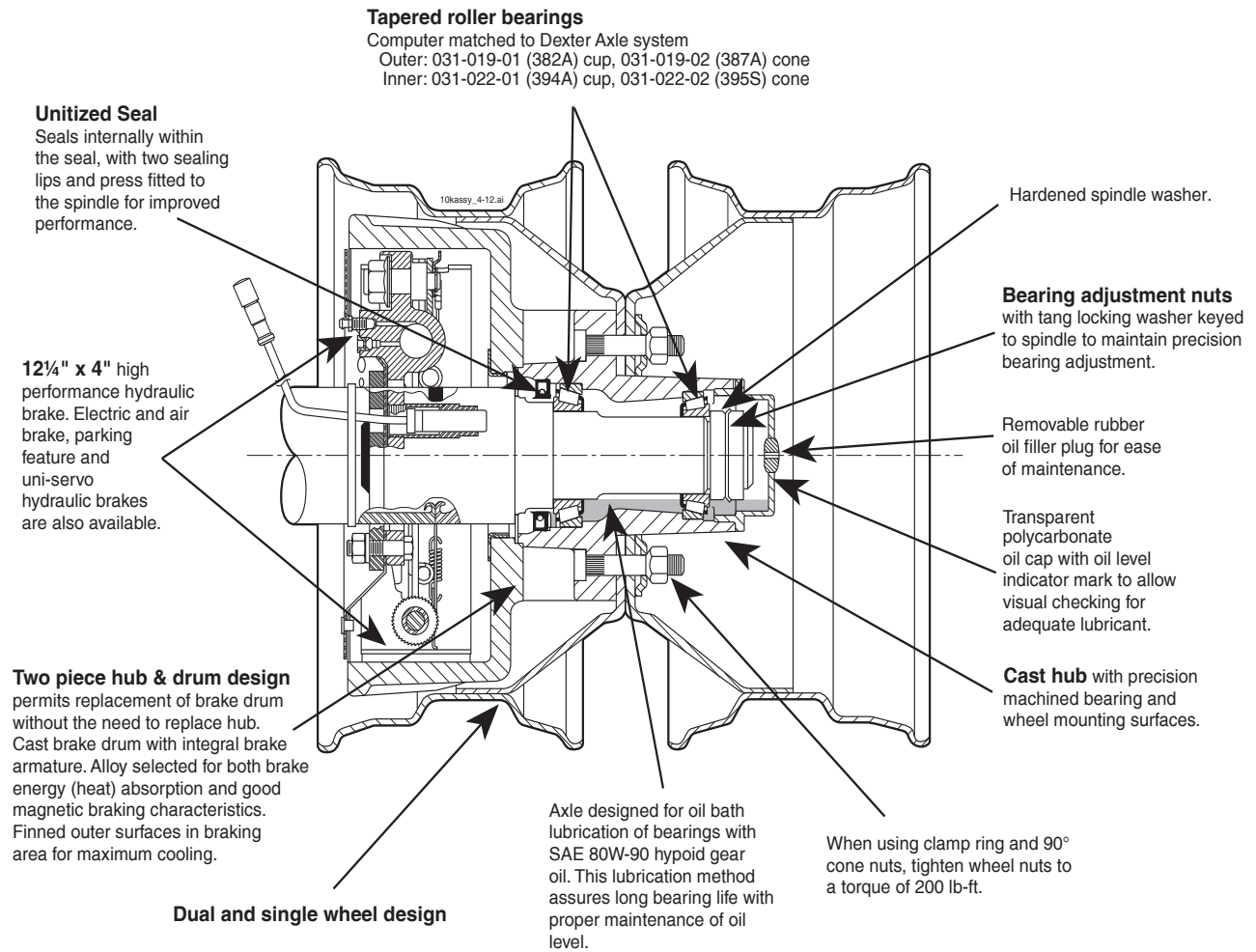

12,000 Lb. Wheel & Hub Assembly

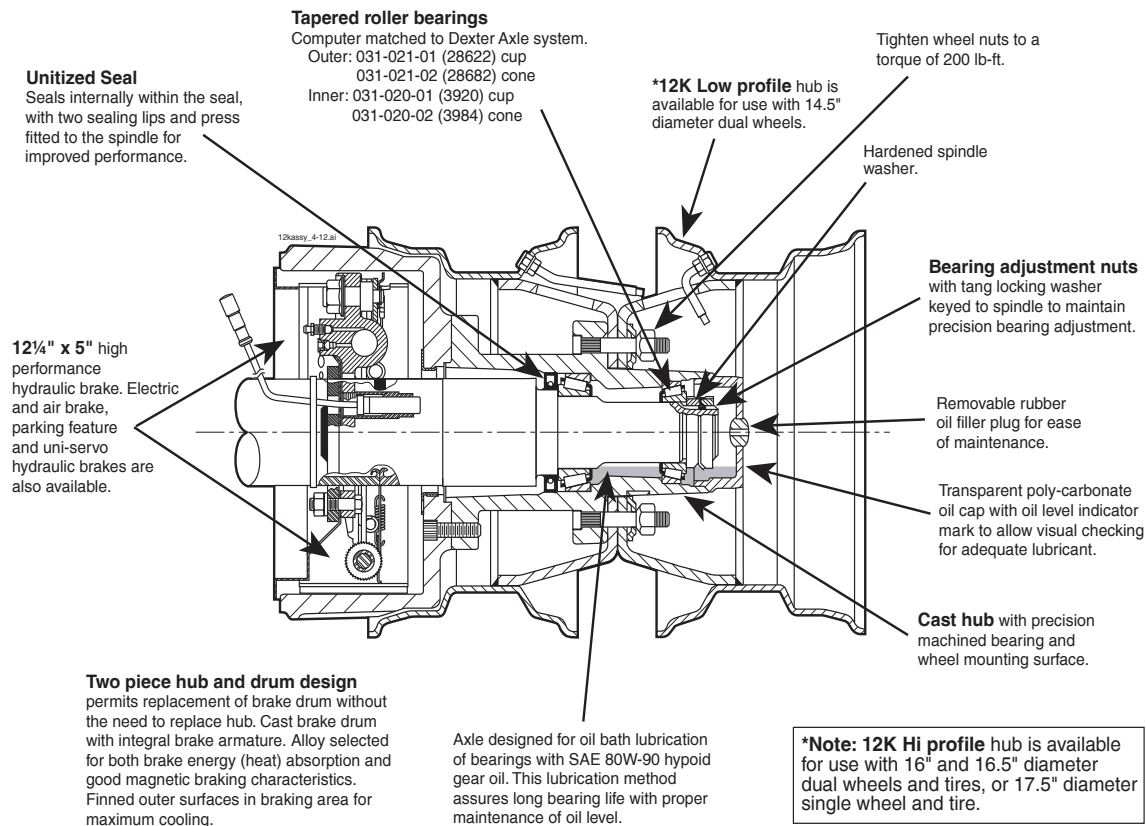

15,000 Lb. Wheel & Hub Assembly

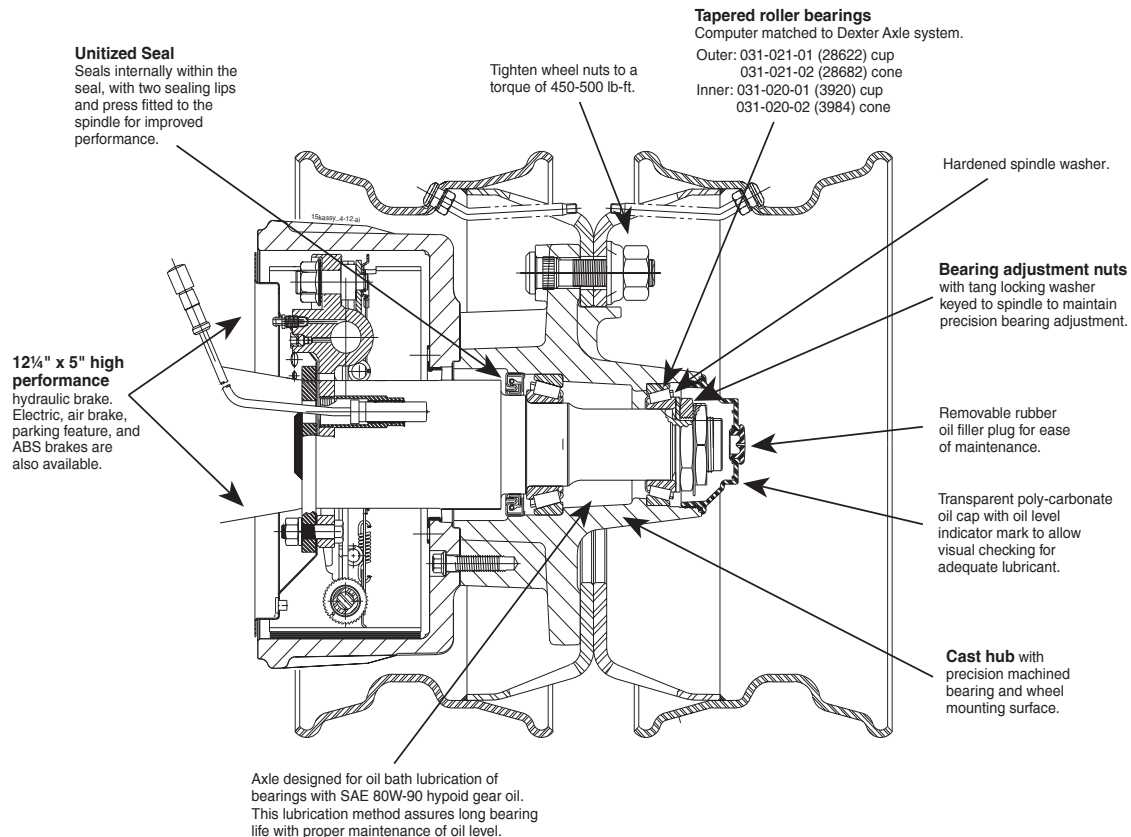

Wheels and Tires



WHEELS & TIRES / AXLE OVERHANG

- Dexter 9K-12K hubs are designed to accept hub-piloted single or dual wheels that have an 8 on 6.50" bolt circle and a 4.75" bore.
- Single wheels should have a wheel offset between 1/2" outset and 3/16" inset for maximum bearing life.
- The Dexter 15K hub is designed to accept hub-piloted dual wheels that have an 8 on 275mm bolt circle and a 221mm bore.

Wheel Dia.	Rim Width Contour	Tire Size Description	SLR	Tire Radius	Width	Capacity Single/Dual	PSI Single/Dual
16.5	6.75	8.00R16.5LT, F	13.20	14.25	9.10	2590/2280	95
16.5	6.75	8.75R16.5LT, E	13.80	14.80	10.00	2680/2360	80
16.5	6.75	8.75R16.5LT, F	13.80	14.80	10.00	2980/2620	95
16.5	6.75	9.5R16.5LT, E	14.30	15.40	10.70	3170/2790	80
16	6.00K	LT235/85R16, D	14.30	15.40	10.30	2623/2381	65
16	6.00K	LT235/85R16, E	14.30	15.40	10.30	3042/2778	80
16	6.00K	LT235/85R16, G	14.30	15.40	10.20	3750/3415	110
17.5	6.75HC	11R17.5HC, G	16.90	18.15	11.80	5050/4430	105/95
17.5	8.25HC	245/70R17.5HC, H	14.20	15.50	9.70	6005/5675	125
17.5	6.75HC	215/75R17.5HC, H	14.00	15.30	9.30	4805/4540	125
22.5	7.5	10R22.5, G	18.80	20.20	11.00	5680/5250	115
14.5	7.00MH	9-14.5LT, F	13.30	14.68	10.10	3230/2840	100
14.5	7.00MH	9-14.5LT, E	13.30	14.68	10.10	2940/2590	85

Axle Overhang Per Side

For Dual Wheel Applications			For Single Wheel Applications		
Axle Model	Min.	Max.	Axle Model	Min.	Max.
D90	13.00	15.50	D90	9.66	15.50
D100GD	13.00	15.50	D100GD	11.75	15.50
D100HD	13.00	15.50	D100HD	12.69	15.19
D120 Lo Profile	16.75	20.50	D120 Lo Profile	16.37	20.12
D120 Hi Profile	13.25	20.20	D120 Hi Profile	12.94	20.19
D150	14.50	16.50	D150	14.06	16.06

To determine frame height, ground clearance, recommended fender height, and center of tire in reference to the frame based on your axle specifications, contact your local Dexter sales representative or Dexter distributor to run ProSpec™.

Recommended Oil Lubrication Specification



Use:	Axle hubs with tapered roller bearing
Service Designation:	API-GL-5
Viscosity:	SAE 80W-90
Pour Point:	-18°C (0°F) Maximum
Additives:	Corrosion and oxidation inhibitors, foam inhibitors, EP additives
Compatibility:	Must be compatible with nitrile and neoprene seals and polycarbonate plastic oil caps
Approved Sources:	

Company	Product Description
Ashland Oil	Valvoline Dura Blend Valvoline Power Lube
CITGO Petroleum Company	CITGO Premium Gear Oil MP Mystik JT-7 Mystik Power Lube
Exxon Company U.S.A.	Gear Oil GX 80W-90
Kendall Refining Company	Kendall NS-MP Hypoid Gear Lube
Lubriplate Division / Fiske Brothers Refining	Lubriplate APG 90
Mobil Oil Corporation	Mobilube SHC Mobil 1 Synthetic Gear Lube
Phillips 66 Petroleum	Superior Multi-Purpose Gear Oil Philguard Gear Oil Philsyn Gear Oil
Pennzoil Products Company	Gear Plus 80W-90 GL-5 Gear Plus Super 75W-90 Gear Plus Super EW 80W-90 Multi-Purpose 4092 Gear Lube
Oil Center Research	Liquid-O-Ring 750 GX
Sun Refining and Marketing Company	Sonoco Ultra Sonoco Dura Gear
Shell Oil Company	Spirax A Spirax G Spirax HD Spirax S
Texaco Oil Company	Multigear EP Multigear SS
Troco Division / Royal Manufacturing	Multigear Select Gear Oil
Union Oil Company	Unocal MP Gear Lube 76 Triton Syn Lube EP

Bearing Adjustment

9K & 10K General Duty, 10K-15K Heavy Duty Axles:

Correct adjustment for all bearings is .001 to .010 end play.

1. Rotate hub assembly slowly while tightening the inner lock nut to 100 lb-ft. to seat the bearings.
2. Loosen the inner lock nut to remove pre-load torque. **Do not rotate the hub.**
3. Finger tighten the inner lock nut and snug.
4. Back inner lock nut out ¼ to ⅜ turn.
5. Install tang washer and outer lock nut. Bend two tangs over inner lock nut. Torque outer lock nut to 100-150 Ft. Lbs., insuring that the inner lock nut does not turn. Bend 2 tangs over flats on outer lock nut to secure.

Dexter Axle Limited Warranty



LIMITED WARRANTY

WHAT PRODUCTS ARE COVERED

All Dexter Axle Company ("Dexter") trailer axles, suspensions, and brake control systems manufactured on or after September 1, 2016, excluding Dexter 6000 series Manufactured Housing Axles. Additional exclusions include the following brands: UFP by Dexter, AL-KO (IAC), Titan Brakes and Actuators by Dexter, and BrakeRite by Dexter products, which are covered under separate warranties.

LIMITED 1 YEAR WARRANTY

As specified in Dexter's current publication "Operation Maintenance Service Manual", grease and oil seals FOR ALL PRODUCTS have a one (1) year limited warranty to the original purchaser from the date of first sale of the trailer incorporating such components. **Except as to grease and oil seals, the following four other warranties are available.**

LIMITED 2 YEAR WARRANTY

Dexter warrants to the original purchaser that its electric/hydraulic brake actuators shall be free from defects in material and workmanship for a period of two (2) years from the date of first sale of the trailer incorporating such components.

LIMITED 5 YEAR WARRANTY

Dexter warrants to the original purchaser that its axles, suspension systems and Genuine Replacement Parts shall be free from defects in material and workmanship for a period of five (5) years. The warranty period shall begin from the date of the original purchase of the trailer and/or Genuine Replacement Parts.

LIMITED 7 YEAR WARRANTY

Dexter warrants to the original purchaser that its Predator Series® electric brake controllers shall be free from defects in material and workmanship for a period of seven (7) years from the date of purchase.

LIMITED 10 YEAR WARRANTY

Dexter warrants to the original purchaser that the suspension components of its Torflex® axles shall be free from defects in material and workmanship for a period of ten (10) years from the date of first sale of the trailer incorporating such suspension components.

EXCLUSIVE REMEDY

Dexter will, at its option, repair or replace the affected components of any defective axle, repair or replace the entire defective axle, or refund the lesser of the original purchase price and the then-current list price of the axle or components. In all cases, a reasonable time period must be allowed for warranty repairs to be completed. Allowance will only be made for installation costs specifically approved by Dexter.

WHAT YOU MUST DO

In order to make a claim under these warranties:

1. You must be the original purchaser of the trailer in which the sprung suspension axles or Torflex® axles or components were originally installed.
2. You must promptly notify Dexter after detection of any defect, but in any case within the applicable warranty period of such defect, and provide us with the axle or applicable component serial number and any substantiation of such defect which may include, but is not limited to, the return of part(s) that we may reasonable request.
3. The axles, suspensions and components must have been installed and maintained in accordance with good industry practice and any specific Dexter recommendations, including those specified in Dexter's current publication "Operation Maintenance Service Manual".

EXCLUSIONS

These warranties do not extend to and do not cover defects caused by:

1. The connecting of brake wiring to the trailer wiring or trailer wiring to the towing vehicle wiring.
2. The attachment of the running gear to the frame.
3. Parts not supplied by Dexter.
4. Any damage whatsoever caused by or related to any alteration of the axle including welding supplemental brackets to the axle.
5. Use of an axle on a unit other than the unit to which it was originally mounted.
6. Normal wear and tear.
7. Improper alignment.
8. Improper installation.
9. Unreasonable use (including failure to provide reasonable and necessary maintenance as specified in Dexter's current publication "Operation Maintenance Service Manual including required maintenance after "Prolonged Storage").
10. Improper torque values and torquing of wheel nuts. (The proper torquing procedure and torque values are contained in Dexter's current publication "Operation Maintenance Service Manual").
11. Cosmetic finish or corrosion.

LIMITATIONS

1. In all cases, Dexter reserves the right to fully satisfy its obligations under the Limited Warranties by refunding the lesser of the original purchase price and the then-current list price of the defective axle (or, if the axle has been discontinued, of the most nearly comparable current product).
2. Dexter reserves the right to furnish a substitute of replacement component or product in the event an axle or any component of the axle is discontinued or is otherwise unavailable.
3. These warranties are nontransferable.

GENERAL

THE FOREGOING WARRANTIES ARE EXCLUSIVE AND IN LIEU OF ALL OTHER WARRANTIES EXCEPT THAT OF TITLE, WHETHER WRITTEN, ORAL OR IMPLIED, IN FACT OR IN LAW (INCLUDING ANY WARRANTY AGAINST INFRINGEMENT OR OF MERCHANTABILITY OR FITNESS FOR A PARTICULAR PURPOSE).

These warranties give you specific legal rights, and you may also have other rights which vary from state to state.

DEXTER HEREBY EXCLUDES INCIDENTAL AND CONSEQUENTIAL DAMAGES, INCLUDING LOSS OF TIME, INCONVENIENCE, LOSS OF USE, TOWING FEES, TELEPHONE CALLS, COST OF MEALS OR LODGING, FOR ANY BREACH OF ANY EXPRESS OR IMPLIED WARRANTY.

Some states do not allow limitations on how long an implied warranty lasts, or the exclusion or limitation if incidental or consequential damages, so the above exclusion or limitation may not apply to you.

Inquiries regarding these warranties should be sent to:

Dexter Axle Company
P.O. Box 250
Elkhart, IN 46515

Note: Current publication "Operation Maintenance Service Manual" can be found at www.dexteraxle.com.

Locations



Genuine Dexter axles and components are available nationwide from our plant locations listed below or through our network of distributors. Check our website for the distributor nearest you.



Dexter - Headquarters

2900 Industrial Parkway East ■ Elkhart, Indiana 46516
 Phone: 574-295-7888 ■ Fax: 574-295-8666
www.dexteraxle.com

Dexter - Pit 12

301 West Pearl Street
 Fremont, Indiana 46737
 Phone: 260-495-5100
 Fax: 260-495-1701

Dexter - Pit 13

500 South 7th Street
 Albion, Indiana 46701
 Phone: 260-636-2195
 Fax: 260-636-3030

Dexter - Pit 15

500 Southeast 27th Street
 El Reno, Oklahoma 73036
 Phone: 405-262-6700
 Fax: 405-262-9089

Dexter - Pit 21

199 Perimeter Road
 Monticello, Georgia 31064
 Phone: 706-468-6495
 Fax: 706-468-2966

Dexter - Pit 23

5600 Bucknell Drive SW
 Atlanta, Georgia 30336
 Phone: 404-477-6899
 Fax: 470-443-1715

Dexter - Pit 24

135 Sunshine Lane
 San Marcos, California 92069
 Phone: 760-744-1610
 Fax: 760-744-1616

Dexter - Pit 25

1041 Baxter Lane
 Winchester, Tennessee 37398
 Phone: 931-967-5101
 Fax: 877-457-9861

Dexter - Pit 27

1845 South 300 West
 Salt Lake City, UT 84115
 Phone: 801-486-4916
 Fax: 801-486-1711

Dexter - Pit 39

902 South Division Street
 Bristol, Indiana 46507
 Phone: 574-848-4491
 Fax: 574-848-4825
www.ventline.com

Dexter - Pit 51

347 King Street West
 Ingersoll, Ontario N5C 2K9
 Phone: 226-242-5291
 Fax: 226-444-0474
www.ingersollaxles.com

Dexter - Pit 52

5885 51 Street SE
 Calgary, Alberta T2C 3V2
 Phone: 587-323-8411
 Fax: 587-327-0129

Dexter - Pit 61

21611 Protecta Drive
 Elkhart, IN 46516
 Phone: 574-294-6651
 Fax: 574-295-6626

Dexter - Pit 62

301 North Kennedy Street
 Shawnee, Oklahoma 74801
 Phone: 405-273-9315
 Fax: 405-273-1054

**NO PART OF THIS CATALOG MAY BE REPRODUCED WITHOUT DEXTER'S PERMISSION.
 ALL PART NUMBERS, DIMENSIONS AND SPECIFICATIONS IN THIS CATALOG ARE SUBJECT
 TO CHANGE WITHOUT NOTICE.**



www.dexteraxle.com

2900 Industrial Parkway East ■ Elkhart, IN 46516
Phone: 574-295-7888 ■ Fax: 574-295-8666

ISO 9001:2015 Certified

